

# Jack and the Map

## DECODABLE WORDS

Target Skill: Short *a*

Al	bat	had	ran
and	can	Jack	Sam
at	cap	last	
back	dad	map	

Previously Taught Skills

be	his	met	we
big	is	on	will
got	it	set	
gust	just	spot	

SKILLS APPLIED IN WORDS IN STORY: consonants; short vowels; double final consonants *ll*; consonants *ck*; blends with *s*; final blends *nd*; final blends *st*; base words and ending *-ed*; long *e* (*e*)

## HIGH-FREQUENCY WORDS

a	here	the	we
after	looked	then	where
are	of	this	
come	out	to	
go	said	was	

© Houghton Mifflin Harcourt Publishing Company

Short *a*

BOOK 1

# Jack and the Map



**High-Frequency Words Taught to Date**

a	brothers	eyes	head	maybe	people	sure	wash
about	brown	fall	hear	me	pictures	surprised	watch
above	buy	family	heard	minute	play	take	water
across	by	far	help	more	please	talk	we
after	call	father	her	most	pull	teacher	were
again	car	few	here	mother	pushed	the	what
all	carry	field	high	my	put	their	where
almost	caught	find	hold	myself	read	there	who
along	city	first	house	near	ready	these	why
always	cold	five	how	never	right	they	window
and	come	fly	I	new	said	think	with
animal	could	follow	idea	night	school	those	work
are	country	food	into	no	second	thought	world
around	covers	for	is	noise	see	three	would
away	cried	four	kinds	nothing	seven	to	write
baby	different	friend	know	now	shall	today	years
ball	do	friendship	large	of	she	together	yellow
be	does	full	laugh	off	should	too	you
bear	done	funny	learning	old	show	took	young
beautiful	don't	give	light	once	sing	toward	your
because	door	go	like	one	small	try	
been	down	goes	listen	only	soil	two	
before	draw	good	little	open	some	under	next
began	earth	great	live	or	sometimes	until	
begins	eat	green	long	our	soon	use	
bird	eight	ground	look	out	sorry	very	
blue	enough	grow	loudly	over	starts	walk	
both	even	happy	loved	own	stories	want	
boy	every	have	make	paper	story	warms	
bring	everyone	he	many	party	studied	was	

**Decoding skills taught to date:** short *a*; consonants; short vowels; double final consonants *ll*; consonants *ck*; blends with *s*; final blends: *nd*; final blends *st*; base words and ending *-ed*; long *e* (*e*)



Jack and Sam met Al. Al had his bat and cap.

"A map!" Al said.

"We are here," said Jack. "Where can we go? Is it on the map?"

# Jack and the Map

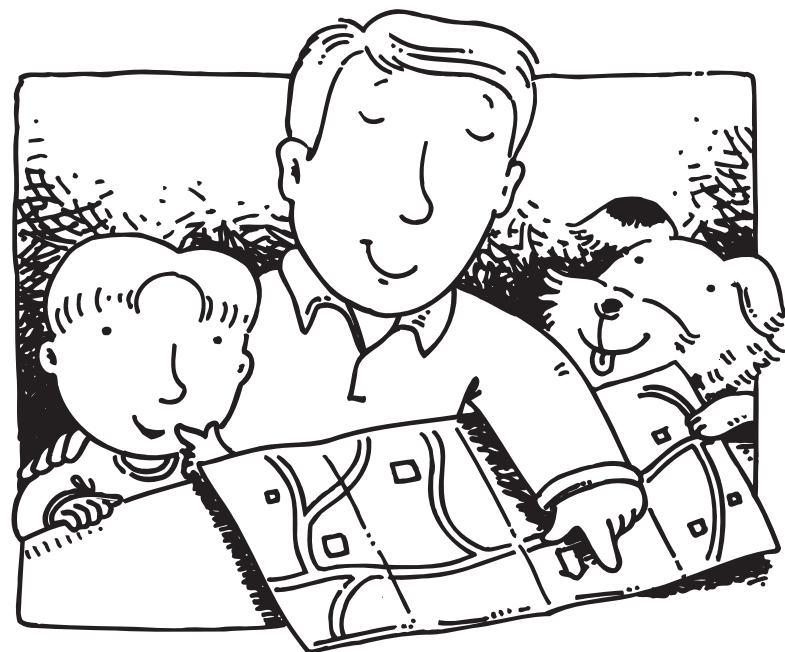

Jack and his dad had a map. It was big. Dad set it out. Dad and Jack looked at it.

"We are here," said Dad.



"Al will be at this spot," said Jack.  
"It is on the map. Come on, Sam!"



Just then, a gust of wind got the map.  
Jack and Sam ran after it.  
At last, Sam got the map back.



# A Cap, a Bag, and a Cat

## DECODABLE WORDS

Target Skill: short *a*

and	can	Dad	happen	man
back	cap	glad	has	Pal
bag	cat	had	Jan	

Previously Taught Skills

bed	dog	is	sit
big	fun	Mom	will
did	in	sad	

SKILLS APPLIED IN WORDS IN STORY: consonants; short vowels; consonants *ck*; double final consonants *ll*; consonant blends with *l*; final consonant blends *nd*

## HIGH-FREQUENCY WORDS

a	love	their
go	read	what
he	the	where

© Houghton Mifflin Harcourt Publishing Company

short *a*

BOOK 2

# A Cap, a Bag, and a Cat



Houghton Mifflin Harcourt.  
The Learning Company™

**High-Frequency Words Taught to Date**

a	brothers	eyes	head	maybe	people	sure	wash
about	brown	fall	hear	me	pictures	surprised	watch
above	buy	family	heard	minute	play	take	water
across	by	far	help	more	please	talk	we
after	call	father	her	most	pull	teacher	were
again	car	few	here	mother	pushed	the	what
all	carry	field	high	my	put	their	where
almost	caught	find	hold	myself	read	there	who
along	city	first	house	near	ready	these	why
always	cold	five	how	never	right	they	window
and	come	fly	I	new	said	think	with
animal	could	follow	idea	night	school	those	work
are	country	food	into	no	second	thought	world
around	covers	for	is	noise	see	three	would
away	cried	four	kinds	nothing	seven	to	write
baby	different	friend	know	now	shall	today	years
ball	do	friendship	large	of	she	together	yellow
be	does	full	laugh	off	should	too	you
bear	don't	funny	learning	old	show	took	young
beautiful	done	give	light	once	sing	toward	your
because	door	go	like	one	small	try	
been	down	goes	listen	only	soil	two	next
before	draw	good	little	open	some	under	
began	earth	great	live	or	sometimes	until	
begins	eat	green	long	our	soon	use	
bird	eight	ground	look	out	sorry	very	
blue	enough	grow	loudly	over	starts	walk	
both	even	happy	loved	own	stories	want	
boy	every	have	make	paper	story	warms	
bring	everyone	he	many	party	studied	was	

---

**Decoding skills taught to date:** short a

# A Cap, a Bag, and a Cat



Pal has the cap, the bag, and the cat.  
Pal had fun! Mom, Dad, and Jan love  
Pal.



Dad is a big man. Dad can sit and  
read.

Dad has a cap. Mom has a bag.  
Pal is their dog. Pal is glad.  
What will happen?



Dad had a cap. Mom had a bag.  
Mom is sad. Where did the cap and  
bag go?



Jan has a cat. Jan is in bed.  
Pal is back. He is glad. What will  
happen?

# Jill Is Sick

## DECODABLE WORDS

Target Skill: short *i*

big	it	sits
hit	Jill	still
in	Jill's	will
is	sick	win

## Previously Taught Skills

and	glad	on
bed	got	play
but	mom	rest
can	must	well
day	not	yay

SKILLS APPLIED IN WORDS IN STORY: short *a*; short *i*; consonants; short vowels; double final consonants *ll*; consonants *-ck*; blends with *l*; blends with *s*; final blends: *nd*; final blends *st*; base words and ending *-s*; possessives with *'s*; long *a* (*ay*)

## HIGH-FREQUENCY WORDS

a	have	she	today
are	her	soon	wants
comes	next	the	what
do	said	to	you

# Jill Is Sick



**High-Frequency Words Taught to Date**

a	bring	every	happy	loudly	out	soon	until
about	brothers	everyone	have	loved	over	sorry	use
above	brown	eyes	he	make	own	starts	very
across	buy	fall	head	many	paper	stories	walk
after	by	family	hear	maybe	party	story	want
again	call	far	heard	me	people	studied	warms
all	car	father	help	minute	pictures	sure	was
almost	carry	few	her	more	play	surprised	wash
along	caught	field	here	most	please	take	watch
always	city	find	high	mother	pull	talk	water
and	cold	first	hold	my	pushed	teacher	we
animal	come	five	house	myself	put	the	were
are	could	fly	how	near	read	their	what
around	country	follow	I	never	ready	there	where
away	covers	food	idea	new	right	these	who
baby	cried	for	into	night	said	they	why
ball	different	four	is	no	school	think	window
be	do	friend	kinds	noise	second	those	with
bear	does	friendship	know	nothing	see	thought	work
beautiful	done	full	large	now	seven	three	world
because	don't	funny	laugh	of	shall	to	would
been	door	give	learning	off	she	today	write
before	down	go	light	old	should	together	years
began	draw	goes	like	once	show	too	yellow
begins	earth	good	listen	one	sing	took	you
bird	eat	great	little	only	small	toward	young
blue	eight	green	live	open	soil	try	your
both	enough	ground	long	or	some	two	
boy	even	grow	look	our	sometimes	under	next

**Decoding skills taught to date:** short *a*, short *i*; consonants; short vowels; double final consonants: *ll*; final blends: *nd*; consonants *-ck*; blends with *l*; blends with *s*; final blends *st*; base words and ending *-s*; possessives with *'s*; long *a* (*ay*)

# Jill Is Sick

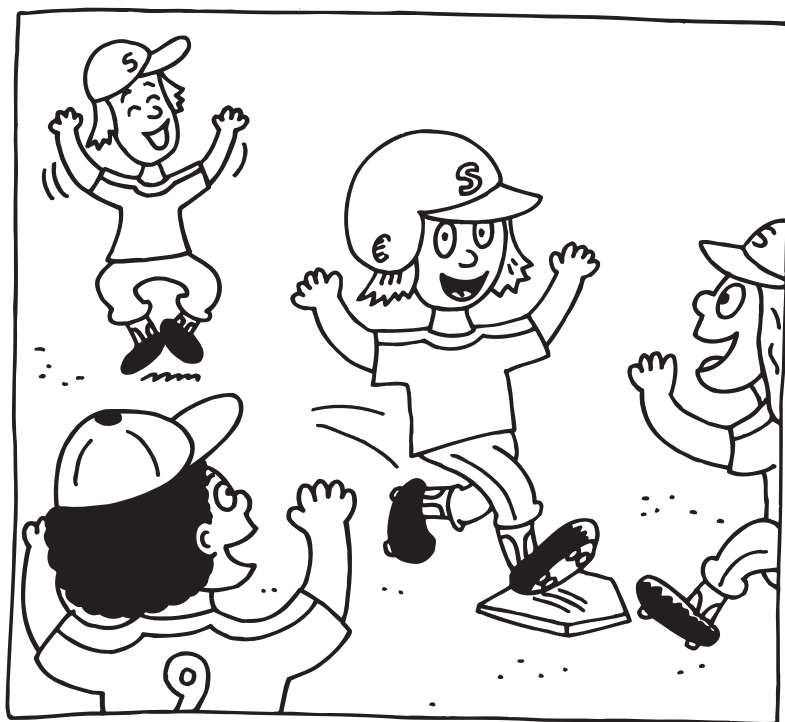

The next day, Jill is glad. She is not sick! She can play!  
It is Jill's big day.  
Jill got a hit. Yay, Jill!

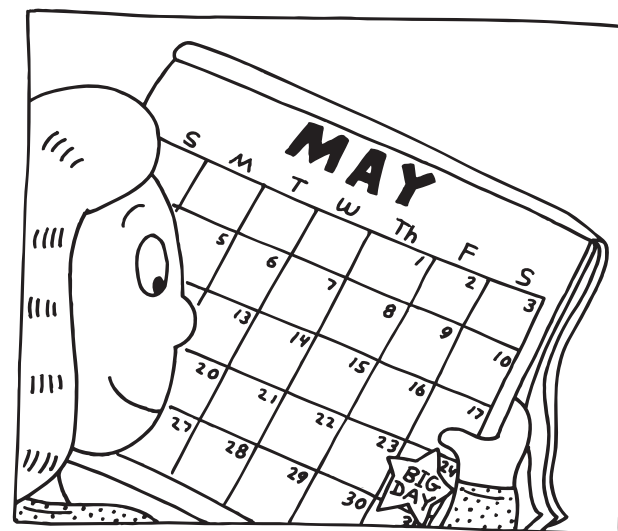

Jill will have a big day. Jill's big day is soon. Jill will play on the big day, but will she win?

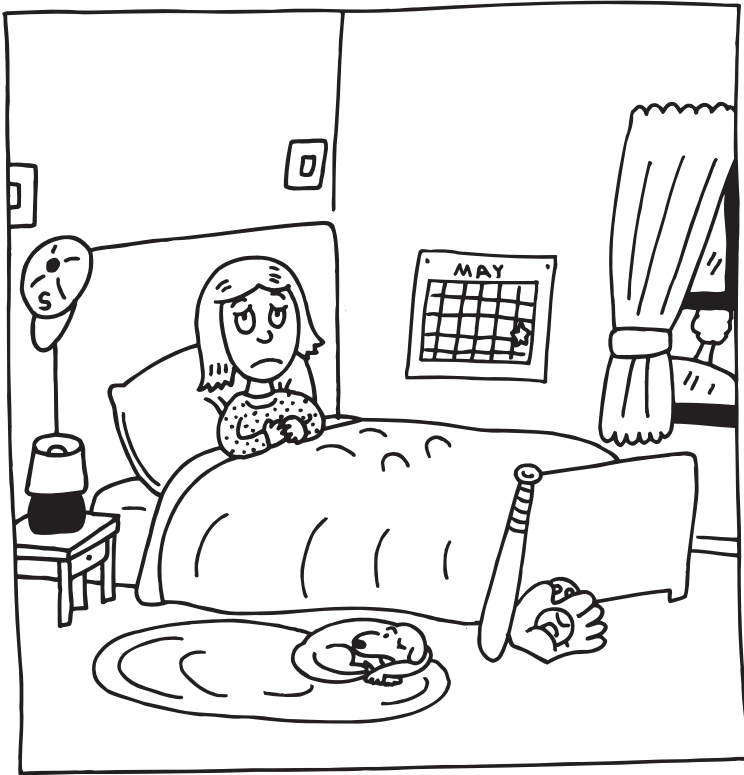

Jill sits in bed and is not well. Jill is sick.

But Jill still wants to play on her big day. What can Jill do?

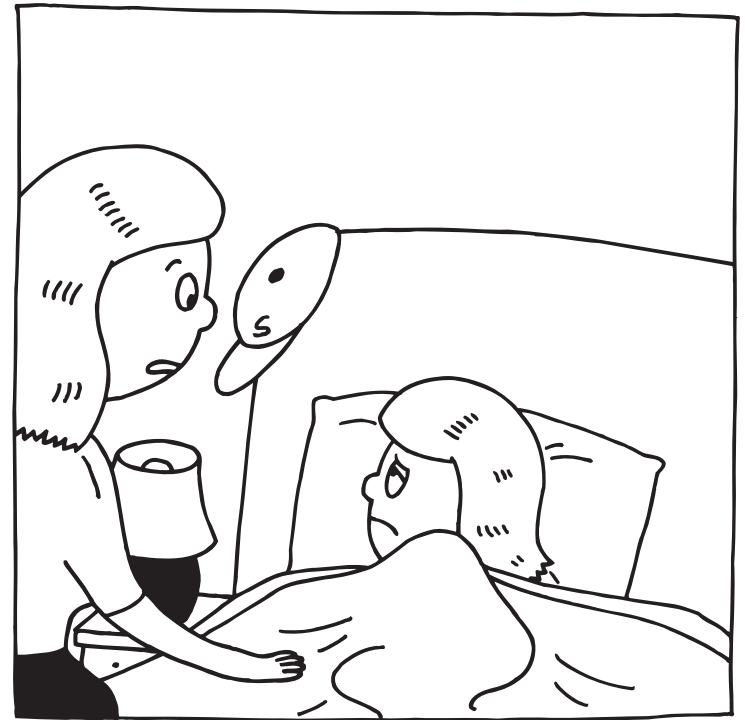

Jill's mom comes in. She sits on Jill's bed.

"Jill, you are sick," said Jill's mom.  
"Today you must rest."



## In the Hot Sand

### DECODABLE WORDS

Target Skill: short *i*

did	dip	in	Kim	will
dig	hit	is	Sid	
digs	hits	it	Tim	

### Previously Taught Skills

and	fun	sand
but	get	stands
can	hot	

SKILLS APPLIED IN WORDS IN STORY: short *a*; consonants; short vowels;  
double final consonants: //; blends with *s*; final blends: *nd*; base words and ending *-s*

### HIGH-FREQUENCY WORDS

a	he	take
ball	make	the
go	play	what

# In the Hot Sand



**High-Frequency Words Taught to Date**

a	bring	every	happy	loudly	out	soon	until
about	brothers	everyone	have	loved	over	sorry	use
above	brown	eyes	he	make	own	starts	very
across	buy	fall	head	many	paper	stories	walk
after	by	family	hear	maybe	party	story	want
again	call	far	heard	me	people	studied	warms
all	car	father	help	minute	pictures	sure	was
almost	carry	few	her	more	play	surprised	wash
along	caught	field	here	most	please	take	watch
always	city	find	high	mother	pull	talk	water
and	cold	first	hold	my	pushed	teacher	we
animal	come	five	house	myself	put	the	were
are	could	fly	how	near	read	their	what
around	country	follow	I	never	ready	there	where
away	covers	food	idea	new	right	these	who
baby	cried	for	into	night	said	they	why
ball	different	four	is	no	school	think	window
be	do	friend	kinds	noise	second	those	with
bear	does	friendship	know	nothing	see	thought	work
beautiful	done	full	large	now	seven	three	world
because	don't	funny	laugh	of	shall	to	would
been	door	give	learning	off	she	today	write
before	down	go	light	old	should	together	years
began	draw	goes	like	once	show	too	yellow
begins	earth	good	listen	one	sing	took	you
bird	eat	great	little	only	small	toward	young
blue	eight	green	live	open	soil	try	your
both	enough	ground	long	or	some	two	
boy	even	grow	look	our	sometimes	under	next

**Decoding skills taught to date:** short *a*, short *i*; consonants; short vowels; double final consonants: //; blends with *s*; final blends: *nd*; base words and ending *-s*



Tim, Kim, and Sid play in the sand.  
Hit it! Get it, Kim!  
It is hot, but it is fun!



Tim digs in the hot sand. He will  
dig and dig.  
What can Tim make in the sand?



Kim hits a ball. Did Kim hit it in the sand?



Sid stands in the hot sand. Will he go in? Will Sid take a dip?

# Yum! Yum! Yum!

## DECODABLE WORDS

**Target Skill:** CVC syllable pattern (closed syllables)

basket	forgot	picnic	sandwich
blanket	napkins	plastic	

**Previously Taught Skills**

bit	cut	in	mug	sit
and	fast	is	on	spill
cub	has	jug	plum	will
cup	hill	mom	run	yum

SKILLS APPLIED IN WORDS IN STORY: short *a*; short *i*; consonants; short vowels; /z/ spelled *s*; double final consonants *ll*; blends with *l*; blends with *s*; final blend *nd*; digraph *ch*; *r*-controlled vowel (*or*)

## HIGH-FREQUENCY WORDS

a	down	the
and	food	water
don't	have	

© Houghton Mifflin Harcourt Publishing Company

CVC syllable pattern  
(closed syllables)

**BOOK 5**

# Yum! Yum! Yum!



Houghton Mifflin Harcourt.  
The Learning Company™

**High-Frequency Words Taught to Date**

a	bring	every	happy	loudly	out	soon	until
about	brothers	everyone	have	loved	over	sorry	use
above	brown	eyes	he	make	own	starts	very
across	buy	fall	head	many	paper	stories	walk
after	by	family	hear	maybe	party	story	want
again	call	far	heard	me	people	studied	warms
all	car	father	help	minute	pictures	sure	was
almost	carry	few	her	more	play	surprised	wash
along	caught	field	here	most	please	take	watch
always	city	find	high	mother	pull	talk	water
and	cold	first	hold	my	pushed	teacher	we
animal	come	five	house	myself	put	the	were
are	could	fly	how	near	read	their	what
around	country	follow	I	never	ready	there	where
away	covers	food	idea	new	right	these	who
baby	cried	for	into	night	said	they	why
ball	different	four	is	no	school	think	window
be	do	friend	kinds	noise	second	those	with
bear	does	friendship	know	nothing	see	thought	work
beautiful	done	full	large	now	seven	three	world
because	don't	funny	laugh	of	shall	to	would
been	door	give	learning	off	she	today	write
before	down	go	light	old	should	together	years
began	draw	goes	like	once	show	too	yellow
begins	earth	good	listen	one	sing	took	you
bird	eat	great	little	only	small	toward	young
blue	eight	green	live	open	soil	try	your
both	enough	ground	long	or	some	two	
boy	even	grow	look	our	sometimes	under	next

**Decoding skills taught to date:** short *a*; short *i*; CVC syllable pattern (closed syllables)



# Yum! Yum! Yum!



© Houghton Mifflin Harcourt Publishing Company

Mom bit the sandwich. Cub bit a plum. Yum, Yum, Yum!



Mom has a basket. Mom and Cub will have a picnic. Mom and Cub run down the hill fast.



Mom and Cub sit on a blanket. Food is in the basket. Water is in the jug.

Cub has a plastic cup. Mom has a mug.

Don't spill, Cub. Mom forgot the napkins.



Mom will cut the sandwich.



# Zip it Up

## DECODABLE WORDS

**Target Skill:** CVC syllable pattern (closed syllables)

backpack pencil plastic  
jacket pencils

### Previously Taught Skills

and	gets	is	on	up
at	has	it	sits	will
back	his	Ken	them	zip
bag	in	lots	things	zips

SKILLS APPLIED IN WORDS IN STORY: short *a*; short *i*; consonants; short vowels; double final consonants *ll*; consonants *-ck*; blends with *s*; digraph *th*; base words and ending *-s*; soft *c*; words ending with *ng*

## HIGH-FREQUENCY WORDS

a	of	puts	the
for	opens	ready	
he	put	school	

© Houghton Mifflin Harcourt Publishing Company

CVC syllable pattern  
(closed syllables)

**BOOK 6**

# Zip it Up

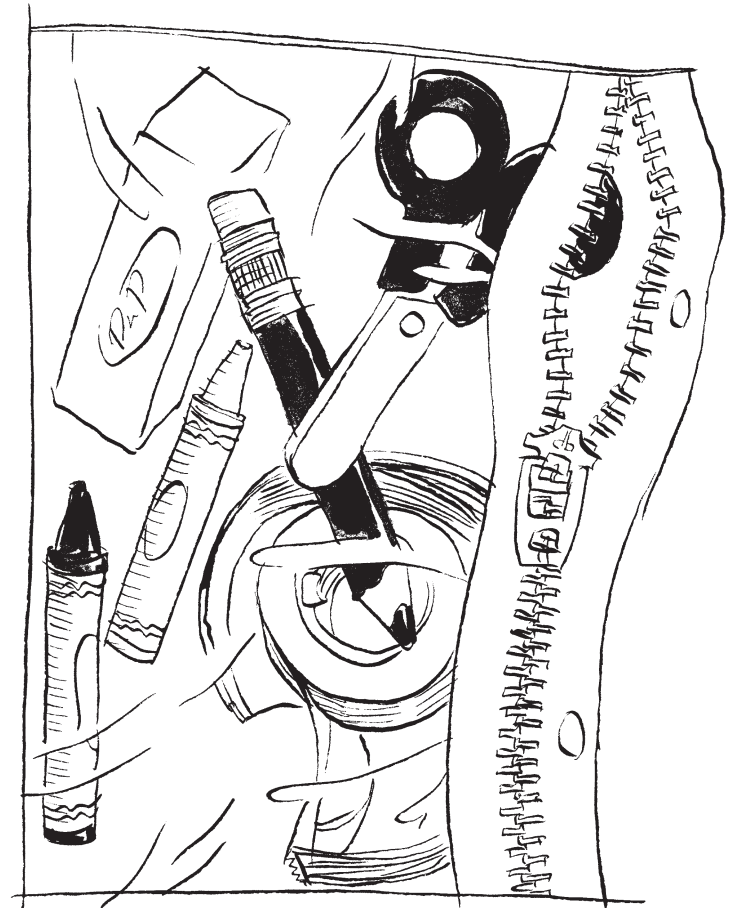

Houghton Mifflin Harcourt.  
The Learning Company™

**High-Frequency Words Taught to Date**

a	bring	every	happy	loudly	out	soon	until
about	brothers	everyone	have	loved	over	sorry	use
above	brown	eyes	he	make	own	starts	very
across	buy	fall	head	many	paper	stories	walk
after	by	family	hear	maybe	party	story	want
again	call	far	heard	me	people	studied	warms
all	car	father	help	minute	pictures	sure	was
almost	carry	few	her	more	play	surprised	wash
along	caught	field	here	most	please	take	watch
always	city	find	high	mother	pull	talk	water
and	cold	first	hold	my	pushed	teacher	we
animal	come	five	house	myself	put	the	were
are	could	fly	how	near	read	their	what
around	country	follow	I	never	ready	there	where
away	covers	food	idea	new	right	these	who
baby	cried	for	into	night	said	they	why
ball	different	four	is	no	school	think	window
be	do	friend	kinds	noise	second	those	with
bear	does	friendship	know	nothing	see	thought	work
beautiful	done	full	large	now	seven	three	world
because	don't	funny	laugh	of	shall	to	would
been	door	give	learning	off	she	today	write
before	down	go	light	old	should	together	years
began	draw	goes	like	once	show	too	yellow
begins	earth	good	listen	one	sing	took	you
bird	eat	great	little	only	small	toward	young
blue	eight	green	live	open	soil	try	your
both	enough	ground	long	or	some	two	
boy	even	grow	look	our	sometimes	under	next

**Decoding skills taught to date:** short *a*; short *i*; CVC syllable pattern (closed syllables)

# Zip it Up



Ken zips pencils and things in  
a plastic bag.

Ken has them for school.



Ken sits at his desk. He opens his  
pencil bag and gets his pencil. Ken will  
put the pencil bag back in his backpack.

Ken is ready for school.



Ken zips his pencil bag in his backpack. It has lots of things in it.



Ken zips up his jacket and puts on his backpack. Ken has his things for school.

# Tick, Tock!

## DECODABLE WORDS

Target Skill: short o

dog	mom	Rob	stop
got	moss	rock	tock
hot	on	Roz	Todd
lot	pond	shops	Todd's

## Previously Taught Skills

and	I	it's	tick
did	in	lunch	went
has	is	Miss	with
hi	it	past	

SKILLS APPLIED IN WORDS IN STORY: short a; short i; short o; consonants; short vowels; double final consonants: ss; consonants: ck; blends with s; final blends: nt, nd, st; digraphs: th, ch, sh; possessives with 's; contractions with 's; long i (i); base words and ending -s

## HIGH-FREQUENCY WORDS

a	said	there	to
car	school	they	today
for	the	time	

© Houghton Mifflin Harcourt Publishing Company

short o

BOOK 7

# Tick, Tock!

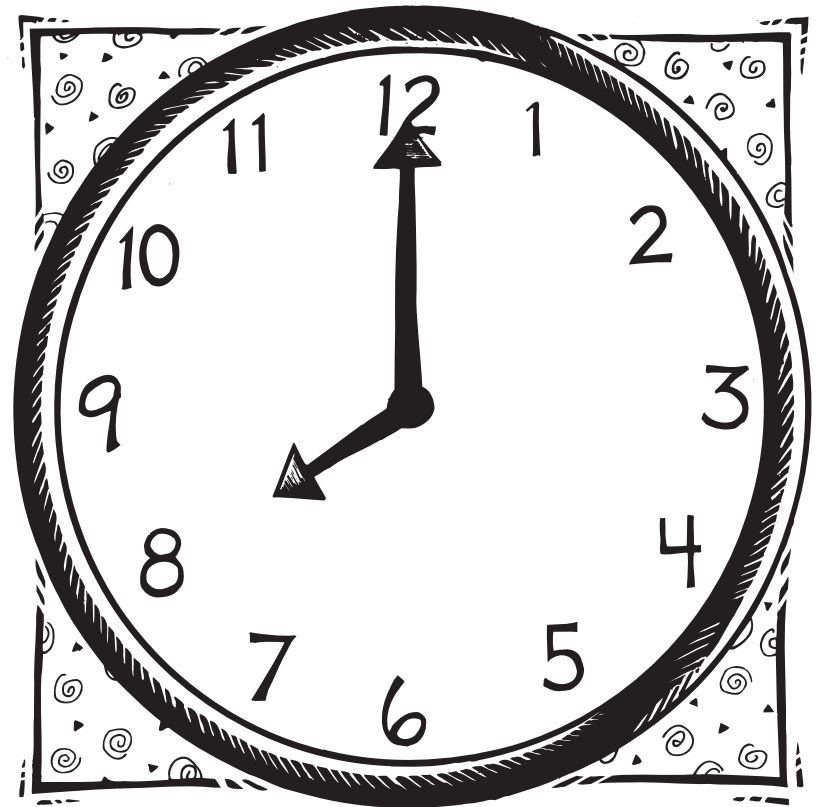

**High-Frequency Words Taught to Date**

a	brothers	eyes	head	maybe	people	sure	wash
about	brown	fall	hear	me	pictures	surprised	watch
above	buy	family	heard	minute	play	take	water
across	by	far	help	more	please	talk	we
after	call	father	her	most	pull	teacher	were
again	car	few	here	mother	pushed	the	what
all	carry	field	high	my	put	their	where
almost	caught	find	hold	myself	read	there	who
along	city	first	house	near	ready	these	why
always	cold	five	how	never	right	they	window
and	come	fly	I	new	said	think	with
animal	could	follow	idea	night	school	those	work
are	country	food	into	no	second	thought	world
around	covers	for	is	noise	see	three	would
away	cried	four	kinds	nothing	seven	to	write
baby	different	friend	know	now	shall	today	years
ball	do	friendship	large	of	she	together	yellow
be	does	full	laugh	off	should	too	you
bear	done	funny	learning	old	show	took	young
beautiful	don't	give	light	once	sing	toward	your
because	door	go	like	one	small	try	
been	down	goes	listen	only	soil	two	children
before	draw	good	little	open	some	under	next
began	earth	great	live	or	sometimes	until	
begins	eat	green	long	our	soon	use	
bird	eight	ground	look	out	sorry	very	
blue	enough	grow	loudly	over	starts	walk	
both	even	happy	loved	own	stories	want	
boy	every	have	make	paper	story	warms	
bring	everyone	he	many	party	studied	was	

**Decoding skills taught to date:** short *a*; short *i*; CVC syllable pattern; short *o*; consonants; short vowels; double final consonants: *ss*; consonants: *ck*; blends with *s*; final blends: *nt*, *nd*, *st*; digraphs: *th*, *ch*, *sh*; possessives with *'s*; contractions with *'s*; long *i* (*i*); base words and ending *-s*

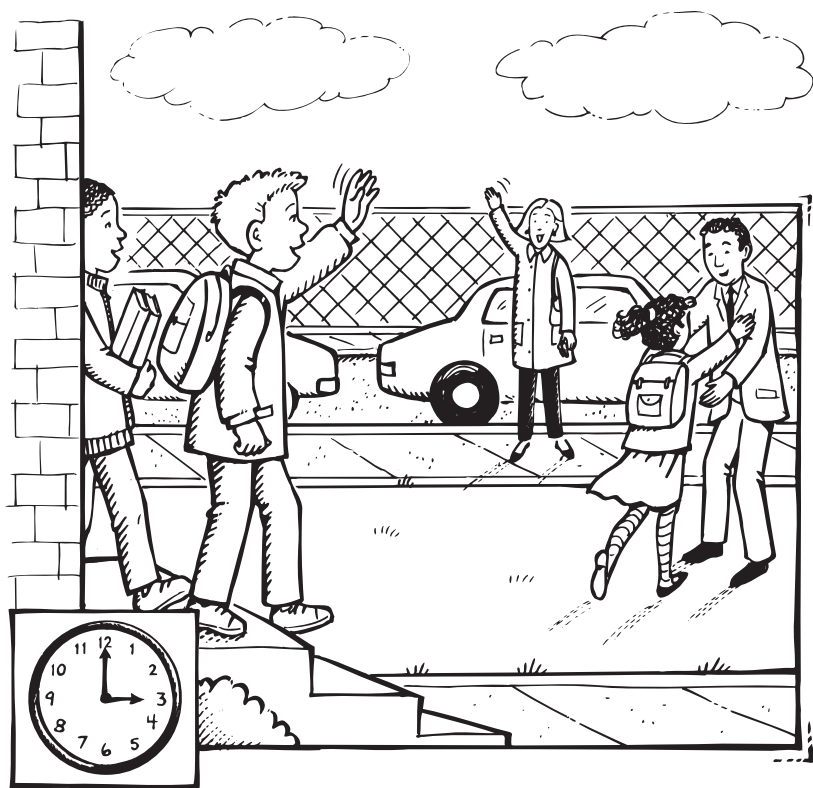

Tick, tock! Tick, tock!  
Todd did a lot today. There is Todd's  
mom.

"Hi, mom!"

# Tick, Tock!

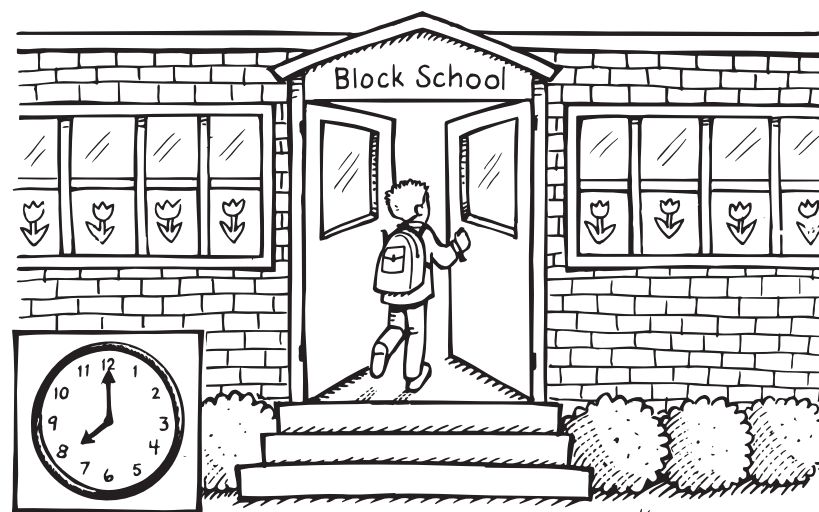

Tick, tock! Tick, tock!  
Todd and Mom got in the car. They  
went past shops. They got to school.

"Stop," said Todd.

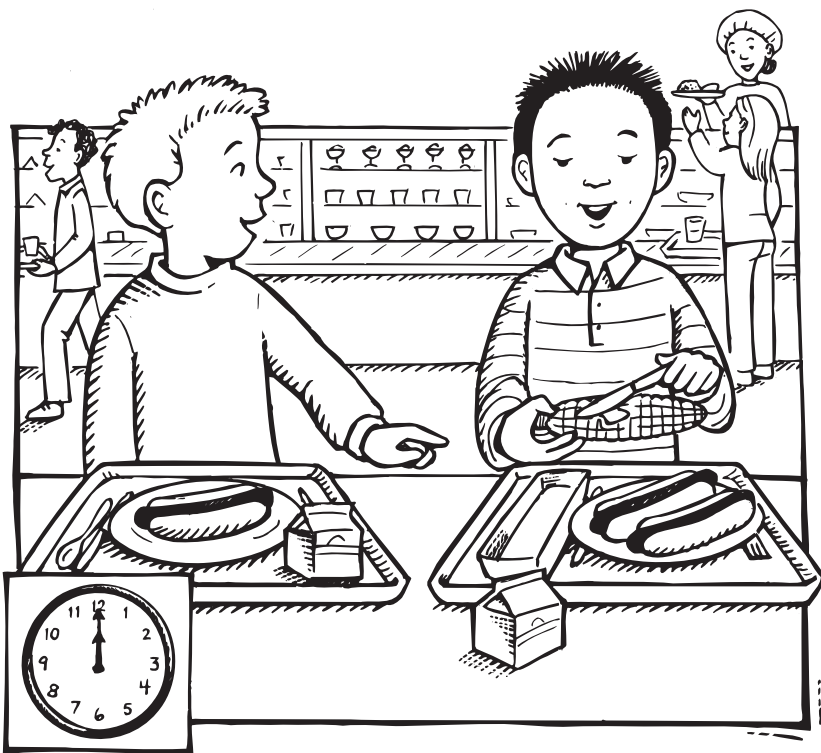

Tick, tock! Tick, tock!  
It's time for lunch. Todd got a hot  
dog. Rob got a lot!

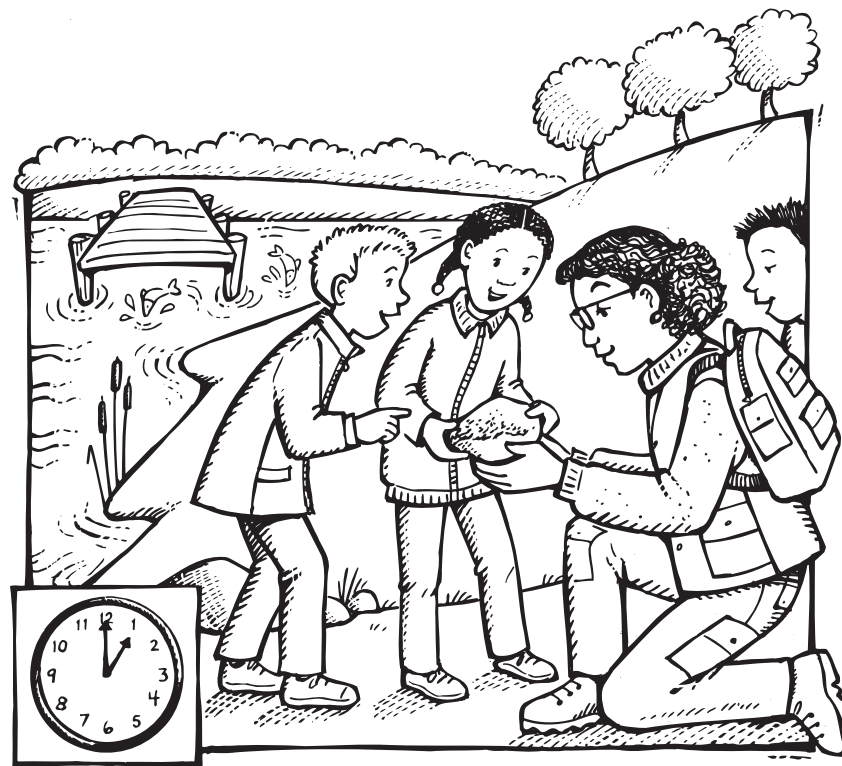

Tick, tock! Tick, tock!  
Todd went to the pond with Miss Roz.  
"I got a rock," said Todd. "It has  
moss on it."



# Big Hot Pot

## DECODABLE WORDS

Target Skill: Short o

hot	not	pot
job	on	stop
lot	Pop	

Previously Taught Skills

am	gave	has	is	that
and	get	him	it	things
ask	getting	his	lid	this
big	glad	I	made	will
can	grins	in	takes	yum

SKILLS APPLIED IN WORDS IN STORY: short *a*; short *i*; short *o*; consonants; short vowels; inflection *-s*; blends with *l*; blends with *r*; final blends *nd*; digraph *th*; base words and endings *-s*, *-ing*; long *a* (*a\_e*); long *i* (*i\_*); words ending with *ng*

## HIGH-FREQUENCY WORDS

a	help	put	time
do	me	puts	to
he	my	the	

# Big Hot Pot



**High-Frequency Words Taught to Date**

a	brothers	eyes	head	maybe	people	sure	wash
about	brown	fall	hear	me	pictures	surprised	watch
above	buy	family	heard	minute	play	take	water
across	by	far	help	more	please	talk	we
after	call	father	her	most	pull	teacher	were
again	car	few	here	mother	pushed	the	what
all	carry	field	high	my	put	their	where
almost	caught	find	hold	myself	read	there	who
along	city	first	house	near	ready	these	why
always	cold	five	how	never	right	they	window
and	come	fly	I	new	said	think	with
animal	could	follow	idea	night	school	those	work
are	country	food	into	no	second	thought	world
around	covers	for	is	noise	see	three	would
away	cried	four	kinds	nothing	seven	to	write
baby	different	friend	know	now	shall	today	years
ball	do	friendship	large	of	she	together	yellow
be	does	full	laugh	off	should	too	you
bear	done	funny	learning	old	show	took	young
beautiful	don't	give	light	once	sing	toward	your
because	door	go	like	one	small	try	
been	down	goes	listen	only	soil	two	children
before	draw	good	little	open	some	under	next
began	earth	great	live	or	sometimes	until	
begins	eat	green	long	our	soon	use	
bird	eight	ground	look	out	sorry	very	
blue	enough	grow	loudly	over	starts	walk	
both	even	happy	loved	own	stories	want	
boy	every	have	make	paper	story	warms	
bring	everyone	he	many	party	studied	was	

**Decoding skills taught to date:** short *a*; short *i*; CVC syllable pattern; short *o*; consonants; short vowels; blends with *l*; blends with *r*; final blends *nd*; digraph *th*; base words and endings *-s*, *-ing*; long *a* (*a\_e*); long *i* (*i\_*); words ending with *ng*

# Big Hot Pot



"That will do it," Pop grins.  
Pop made a lot in the big hot pot.  
He gave me a lot.  
Yum! Yum!



This is my pop. He has a big pot.  
The pot will get hot.  
I can help him put things in the  
big pot.



Pop takes a lid and puts it on the big pot. That is his job. The pot is getting hot.

I am glad to help Pop.



The pot is hot! It is time to stop.  
"Can I get a lot?" I ask.

# Big Trucks

## DECODABLE WORDS

Target Skill: short u

Bud	dumps	rush	truck
bus	fun	sun	trucks
Chun	mud	thud	up
dump	runs	thump	

## Previously Taught Skills

am	get	his	man	then
and	gets	hot	Miss	thick
at	glad	I	on	this
back	go	in	pals	when
big	has	is	picks	will
day	hats	it	plop	
down	hills	lots	sit	

SKILLS APPLIED IN WORDS IN STORY: short a; short i; CVC syllable pattern; short o; short u; consonants; short vowels; double final consonants: ll; double final consonants: ss; inflection -s; consonants ck; blends with l; blends with r; blends with s; final blend mp; final blend nd; digraph th; digraph ch; digraph sh; digraph wh; long a (ay); long i (CV); long o (CV); vowel combination ow

## HIGH-FREQUENCY WORDS

a	children	school	work
all	have	the	
are	look	to	
be	of	today	

© Houghton Mifflin Harcourt Publishing Company

short u

BOOK 9

# Big Trucks

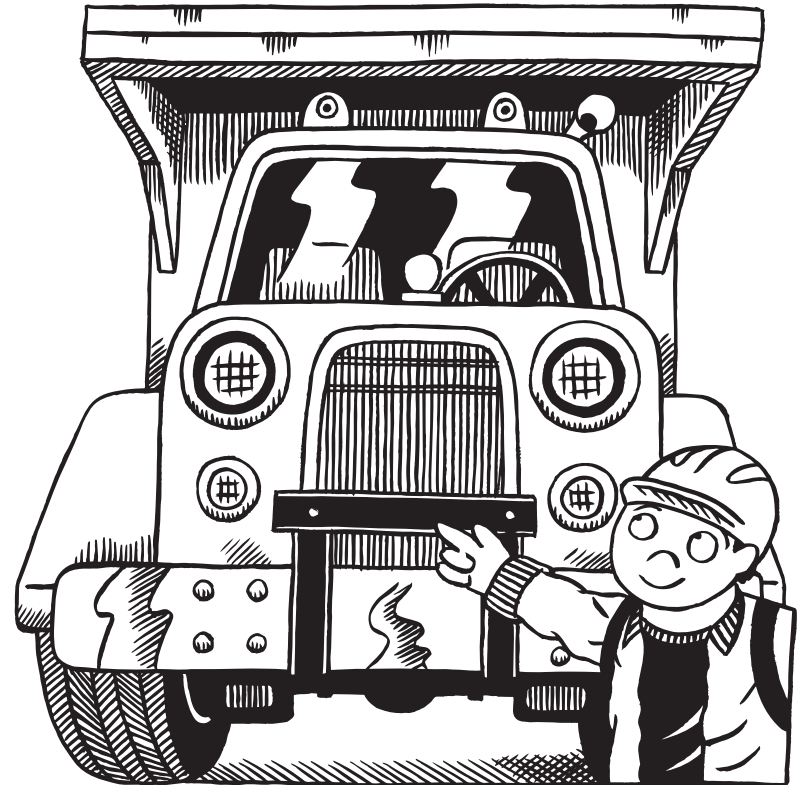

Houghton Mifflin Harcourt.  
The Learning Company™

**High-Frequency Words Taught to Date**

a	brothers	eyes	head	maybe	people	sure	wash
about	brown	fall	hear	me	pictures	surprised	watch
above	buy	family	heard	minute	play	take	water
across	by	far	help	more	please	talk	we
after	call	father	her	most	pull	teacher	were
again	car	few	here	mother	pushed	the	what
all	carry	field	high	my	put	their	where
almost	caught	find	hold	myself	read	there	who
along	city	first	house	near	ready	these	why
always	cold	five	how	never	right	they	window
and	come	fly	I	new	said	think	with
animal	could	follow	idea	night	school	those	work
are	country	food	into	no	second	thought	world
around	covers	for	is	noise	see	three	would
away	cried	four	kinds	nothing	seven	to	write
baby	different	friend	know	now	shall	today	years
ball	do	friendship	large	of	she	together	yellow
be	does	full	laugh	off	should	too	you
bear	done	funny	learning	old	show	took	young
beautiful	don't	give	light	once	sing	toward	your
because	door	go	like	one	small	try	
been	down	goes	listen	only	soil	two	children
before	draw	good	little	open	some	under	next
began	earth	great	live	or	sometimes	until	
begins	eat	green	long	our	soon	use	
bird	eight	ground	look	out	sorry	very	
blue	enough	grow	loudly	over	starts	walk	
both	even	happy	loved	own	stories	want	
boy	every	have	make	paper	story	warms	
bring	everyone	he	many	party	studied	was	

**Decoding skills taught to date:** short *a*; short *i*; CVC syllable pattern; short *o*; short *u*; consonants; short vowels; double final consonants *ll*; double final consonants *ss*; inflection *-s*; consonants *ck*; blends with *t*; blends with *r*; blends with *s*; final blend *mp*; final blend *nd*; digraph *th*; digraph *ch*; digraph *sh*; digraph *wh*; long *a* (*ay*); long *i* (*CV*); long *o* (*CV*); vowel combination *ow*

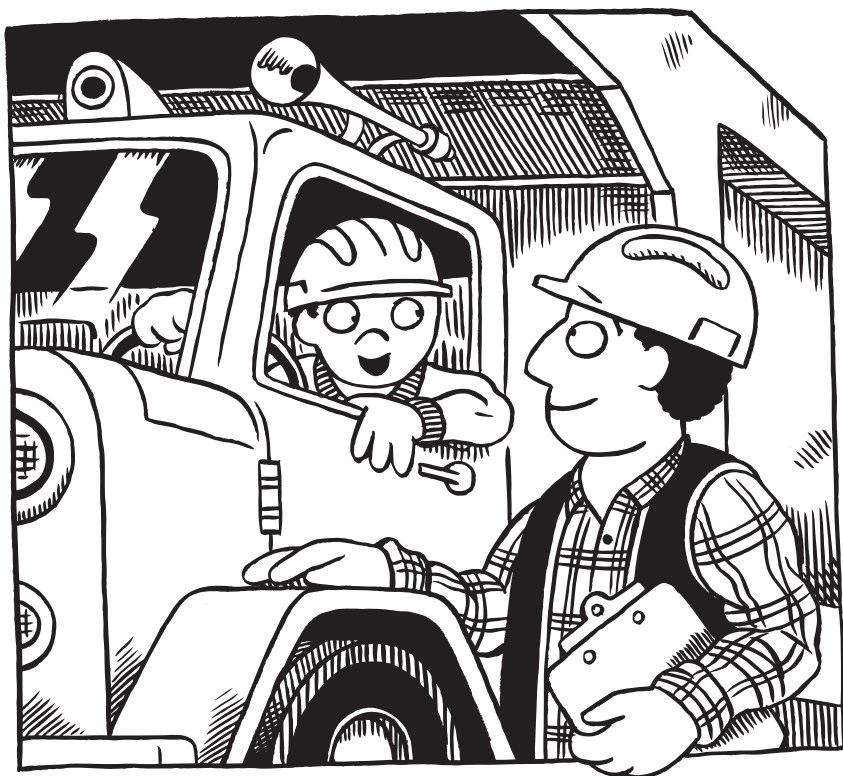

© Houghton Mifflin Harcourt Publishing Company

The man picks up Bud. Bud gets to sit in the dump truck!

“When I am big, I will work on a big truck!”

Short u

**BOOK 9**

# Big Trucks

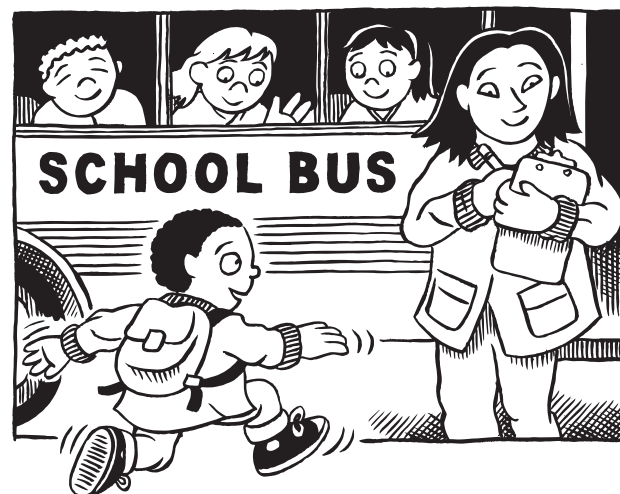

Bud gets up and runs to school. Then Bud and his pals rush to the bus. Miss Chun is at the bus.

The children are glad to get on the bus. Today will be fun!





Bud and his pals have hats on. Look!  
It is a big dump truck! This truck has  
lots of thick mud.

The back is up. Then it dumps the  
mud! PLOP! THUD! THUMP!



Trucks go up and down hills. Big  
trucks work all day in the hot sun.



## Pug and the Bug

### DECODABLE WORDS

Target Skill: short *u*

bug	fun	Pug	sun
buns	jump	rug	
but	jumps	runs	

### Previously Taught Skills

and	gets	is	on	will
at	has	look	out	
big	he	looks	sit	
did	his	not	slid	
dog	in	now	still	

SKILLS APPLIED IN WORDS IN STORY: short *a*; short *i*; CVC syllable pattern; short *o*; short *u*; consonants; short vowels; inflection -s; double final consonants: *ll*; long *e* (CV); blends with *s*; final blend *mp*; final blend *nd*; vowel digraph *oo* /*ōō*/; vowel combinations *ou*, *ow*

### HIGH-FREQUENCY WORDS

a	away	near	or
after	have	next	the

short *u*

**BOOK 10**

# Pug and the Bug

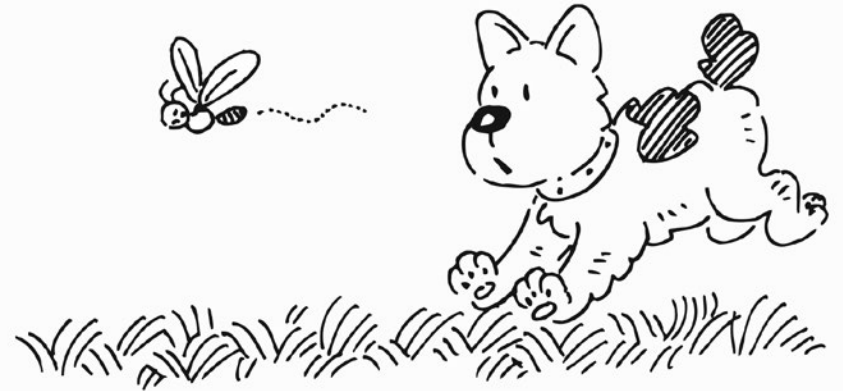

**High-Frequency Words Taught to Date**

a	brothers	eyes	head	maybe	people	sure	wash
about	brown	fall	hear	me	pictures	surprised	watch
above	buy	family	heard	minute	play	take	water
across	by	far	help	more	please	talk	we
after	call	father	her	most	pull	teacher	were
again	car	few	here	mother	pushed	the	what
all	carry	field	high	my	put	their	where
almost	caught	find	hold	myself	read	there	who
along	city	first	house	near	ready	these	why
always	cold	five	how	never	right	they	window
and	come	fly	I	new	said	think	with
animal	could	follow	idea	night	school	those	work
are	country	food	into	no	second	thought	world
around	covers	for	is	noise	see	three	would
away	cried	four	kinds	nothing	seven	to	write
baby	different	friend	know	now	shall	today	years
ball	do	friendship	large	of	she	together	yellow
be	does	full	laugh	off	should	too	you
bear	done	funny	learning	old	show	took	young
beautiful	don't	give	light	once	sing	toward	your
because	door	go	like	one	small	try	
been	down	goes	listen	only	soil	two	children
before	draw	good	little	open	some	under	next
began	earth	great	live	or	sometimes	until	
begins	eat	green	long	our	soon	use	
bird	eight	ground	look	out	sorry	very	
blue	enough	grow	loudly	over	starts	walk	
both	even	happy	loved	own	stories	want	
boy	every	have	make	paper	story	warms	
bring	everyone	he	many	party	studied	was	

**Decoding skills taught to date:** short *a*, short *i*, CVC syllable pattern, short *o*, short *u*; consonants; short vowels; inflection *-s*; double final consonants *ll*; long *e* (CV); blends with *s*; final blend *mp*; final blend *nd*; vowel digraph *oo*/*ōō*; vowel combinations *ou*, *ow*



Now Pug is on his rug, and the big bug is on Pug!

Did Pug have fun or not?

# Pug and the Bug

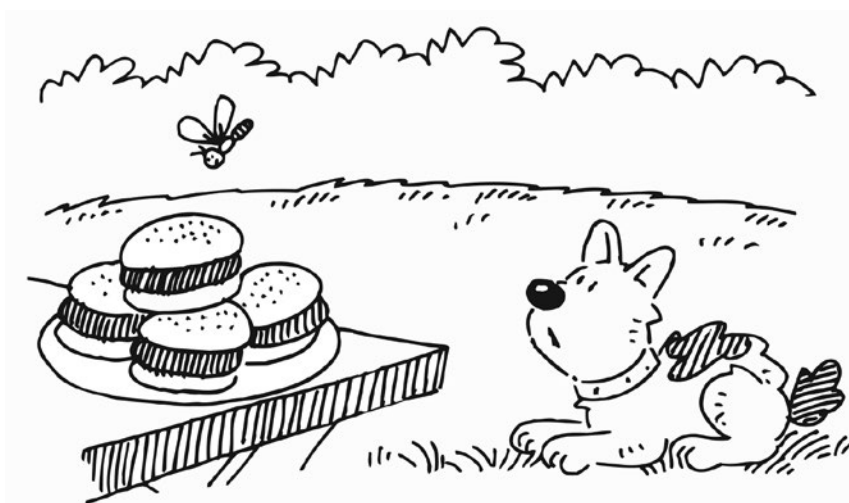

Pug the dog is in the sun. He looks at a big bug!

Will Pug sit still in the sun, or will he jump at the bug?



The big bug is near the buns. Pug jumps at the bug.

The bug gets away. Pug has the buns but not the bug!



Next, Pug runs after the big bug. He runs on a rug.

Look out, Pug! Pug slid on the rug!

# What a Mess!

## DECODABLE WORDS

Target Skill: Short e

bed	Fred	met	well
bet	help	next	went
Beth	left	red	yes
Beth's	let's	shed	yet
dress	mess	tell	

## Previously Taught Skills

and	doll	lots	sock
asked	he	on	this
big	I	pick	too
can	in	room	toys
Dad	is	rug	up
did	it	see	you

SKILLS APPLIED IN WORDS IN STORY: short *a*; short *i*; CVC syllable pattern; short *o*; short *u*; short *e*; consonants; short vowels; final double consonants *ll*; final double consonants *ss*; consonants *ck*; long *e* (CV, *ee*); long *i* (CV); inflections *-s*, *-ed*; blends with *r*; final blends; final blend *nt*; final blend *nd*; digraph *th*; possessives with *'s*; digraph *sh*; digraph *wh*; contractions with *'s*; vowel digraphs/spelling patterns *oo*, *ou*; vowel combination *oy*

## HIGH-FREQUENCY WORDS

a	said	to	were
of	the	was	what

# What a Mess!

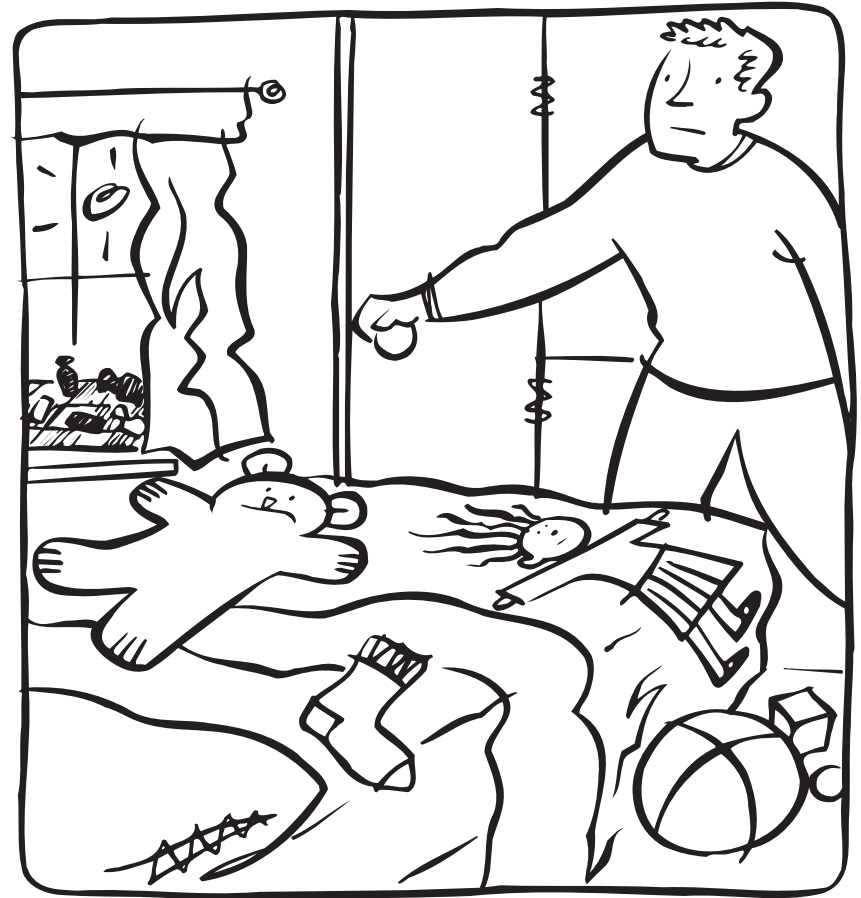

**High-Frequency Words Taught to Date**

a	brothers	eyes	head	maybe	people	sure	wash
about	brown	fall	hear	me	pictures	surprised	watch
above	buy	family	heard	minute	play	take	water
across	by	far	help	more	please	talk	we
after	call	father	her	most	pull	teacher	were
again	car	few	here	mother	pushed	the	what
all	carry	field	high	my	put	their	where
almost	caught	find	hold	myself	read	there	who
along	city	first	house	near	ready	these	why
always	cold	five	how	never	right	they	window
and	come	fly	I	new	said	think	with
animal	could	follow	idea	night	school	those	work
are	country	food	into	no	second	thought	world
around	covers	for	is	noise	see	three	would
away	cried	four	kinds	nothing	seven	to	write
baby	different	friend	know	now	shall	today	years
ball	do	friendship	large	of	she	together	yellow
be	does	full	laugh	off	should	too	you
bear	done	funny	learning	old	show	took	young
beautiful	don't	give	light	once	sing	toward	your
because	door	go	like	one	small	try	
been	down	goes	listen	only	soil	two	children
before	draw	good	little	open	some	under	next
began	earth	great	live	or	sometimes	until	
begins	eat	green	long	our	soon	use	
bird	eight	ground	look	out	sorry	very	
blue	enough	grow	loudly	over	starts	walk	
both	even	happy	loved	own	stories	want	
boy	every	have	make	paper	story	warms	
bring	everyone	he	many	party	studied	was	

**Decoding skills taught to date:** short *a*; short *i*; CVC syllable pattern; short *o*; short *u*; short *e*; consonants; short vowels; final double consonants *ll*; final double consonants *ss*; consonants *ck*; long *e* (*CV, ee*); long *i*; inflections *-s*, *-ed*; blends with *r*; final blends; final blend *nt*; final blend *nd*; digraph *th*; possessives with *'s*; digraph *sh*; digraph *wh*; contractions with *'s*; vowel digraphs/spelling patterns *oo*, *ou*; vowel combination *oy*



"Let's tell Beth to pick up this mess," said Fred.

"Well, can Fred help?" Beth asked Dad.

"Yes, Fred can help!"

## What a Mess!



Dad went to Beth's room. A doll in a dress and a red sock were on Beth's bed. Lots of toys were on Beth's rug.

"What a mess!" said Dad.

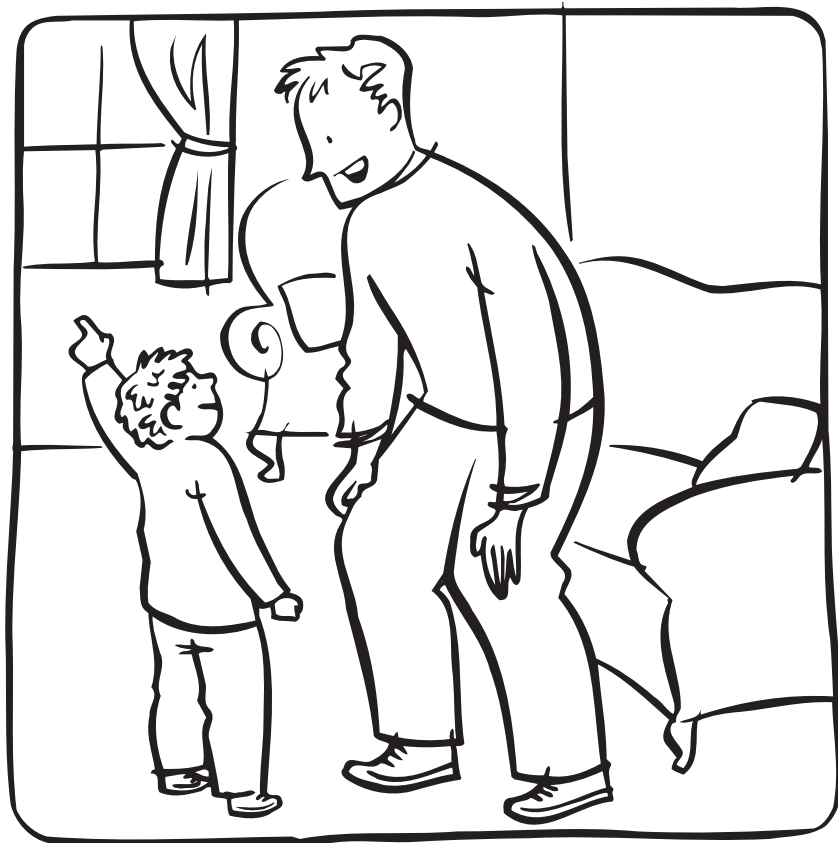

Dad left Beth's mess. He met Fred in the next room.

"Did you see Beth yet?" asked Dad.

"I bet Beth is in the shed," said Fred.



Fred and Dad went to the shed. Beth was in the shed. It was a big mess, too!

"This is a mess!" said Dad.



## Dogs at the Vet

### DECODABLE WORDS

Target Skill: Short e

Ed	met	pets	them	wet
get	Peg	Ted	vet	yell
Jed	pet	tells	went	yet

### Previously Taught Skills

and	go	it's	snacks
at	good	like	take
back	has	look	time
but	he	not	with
Dad	hide	out	
dogs	is	run	
for	it	sits	

SKILLS APPLIED IN WORDS IN STORY: short a; short i; CVC syllable pattern; short o; short u; short e; consonants; inflection -s; short vowels; double final consonants //; consonants ck; blends with s; final blend nt; final blend nd; digraph th; r-controlled vowel or; long a (CVGe); long e (CV); long i (CVCe); long o (CV); vowel digraph /ōō/ oo; vowel combination ou; contractions with 's

### HIGH-FREQUENCY WORDS

are	do	the	to
children	have	they	want

# Dogs at the Vet

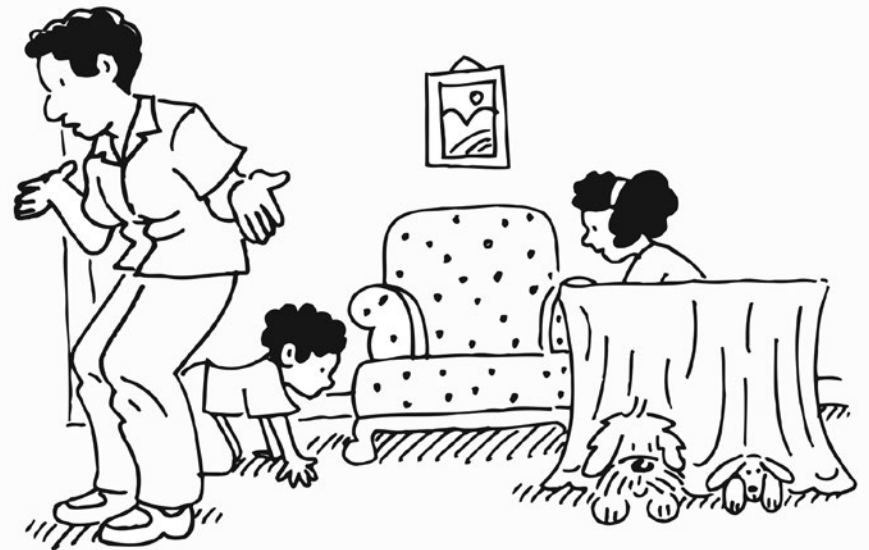

**High-Frequency Words Taught to Date**

a	brothers	eyes	head	maybe	people	sure	wash
about	brown	fall	hear	me	pictures	surprised	watch
above	buy	family	heard	minute	play	take	water
across	by	far	help	more	please	talk	we
after	call	father	her	most	pull	teacher	were
again	car	few	here	mother	pushed	the	what
all	carry	field	high	my	put	their	where
almost	caught	find	hold	myself	read	there	who
along	city	first	house	near	ready	these	why
always	cold	five	how	never	right	they	window
and	come	fly	I	new	said	think	with
animal	could	follow	idea	night	school	those	work
are	country	food	into	no	second	thought	world
around	covers	for	is	noise	see	three	would
away	cried	four	kinds	nothing	seven	to	write
baby	different	friend	know	now	shall	today	years
ball	do	friendship	large	of	she	together	yellow
be	does	full	laugh	off	should	too	you
bear	done	funny	learning	old	show	took	young
beautiful	don't	give	light	once	sing	toward	your
because	door	go	like	one	small	try	
been	down	goes	listen	only	soil	two	children
before	draw	good	little	open	some	under	next
began	earth	great	live	or	sometimes	until	
begins	eat	green	long	our	soon	use	
bird	eight	ground	look	out	sorry	very	
blue	enough	grow	loudly	over	starts	walk	
both	even	happy	loved	own	stories	want	
boy	every	have	make	paper	story	warms	
bring	everyone	he	many	party	studied	was	

**Decoding skills taught to date:** short *a*; short *i*; CVC syllable pattern; short *o*; short *u*; short *e*; consonants; short vowels; inflection *-s*; double final consonants *ll*; consonants *ck*; blends with *s*; final blend *nt*; final blend *nd*; digraph *th*; contractions with *'s*; *r*-controlled vowel *or*; long *a* (CVCe); long *e* (CV); long *i* (CVCe); long *o* (CV); vowel digraph /ōō/ *oo*; vowel combination *ou*



At the vet, Dad pets Ed. Ted and Peg pet Jed.

The vet has snacks for the dogs. Ed and Jed like the vet!

## Dogs at the Vet



Dad sits with Peg and Ted. He tells them it is time to take the pets to the vet.

Ed and Jed are good pets, but they have not met the vet.

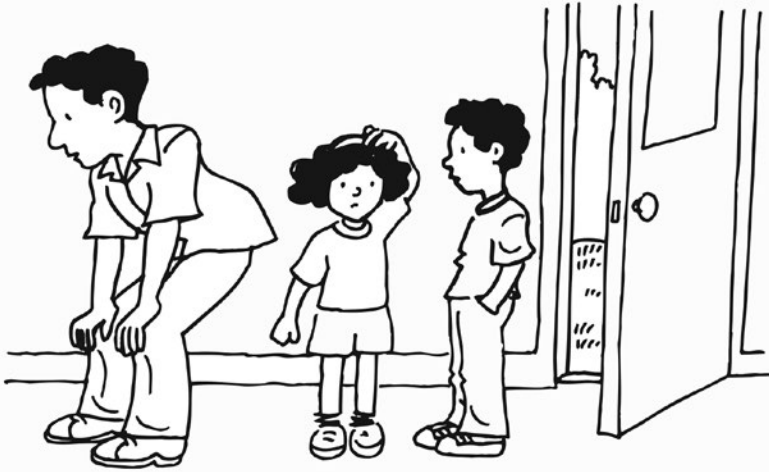

Ed and Jed run and hide. They do not want to go to the vet yet.

Dad and the children look for Ed and Jed.

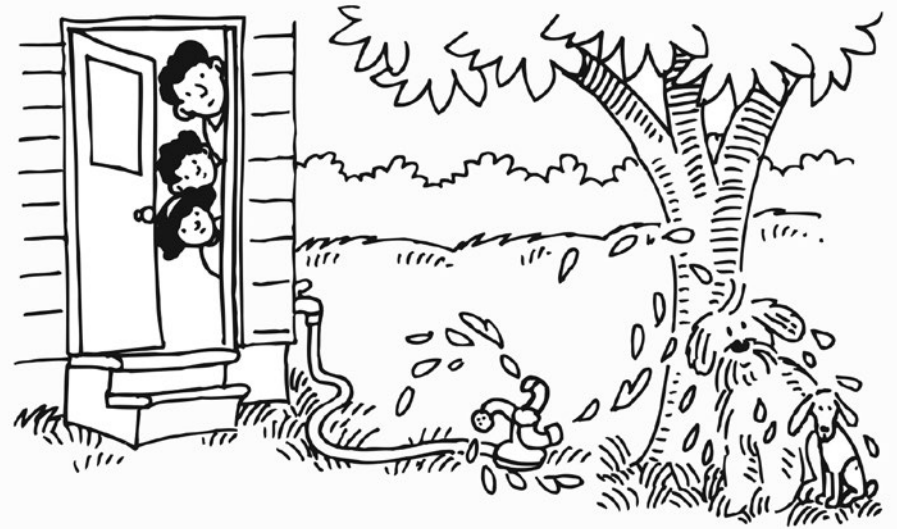

“The dogs went out back!” Peg and Ted yell.

Ed and Jed get wet. But it’s time to go to the vet!

# The Hunt Game

## DECODABLE WORDS

**Target Skill:** CVC syllable pattern (closed syllables)

basket	cannot	cotton	mittens	puppet
button	cobweb	helmet	napkins	sunset

### Previously Taught Skills

and	fun	in	make	thing
asked	game	is	me	things
be	get	it	Mom	this
big	go	last	next	we
bike	got	let	not	went
but	grin	let's	on	will
can	hands	list	play	with
Dad	hunt	lots	spots	
end	I	made	then	

SKILLS APPLIED IN WORDS IN STORY: short *a*; short *i*; short *o*; short *u*; short *e*; CVC syllable pattern (closed); consonants; short vowels; double final consonants //; long *a* (CVGe, ay); long *i* (CV, CVGe); long *e* (CV); long *o* (CV); blends with *l*; blends with *r*; blends with *s*; final blend *nd*; final blend *ng*; final blend *nt*; final blends; inflections -s, -ed; contractions with 's; digraph *th*

## HIGH-FREQUENCY WORDS

a	of	picture	the	was
how	our	said	to	

© Houghton Mifflin Harcourt Publishing Company

CVC syllable pattern  
(closed syllables)

**BOOK 13**

# The Hunt Game

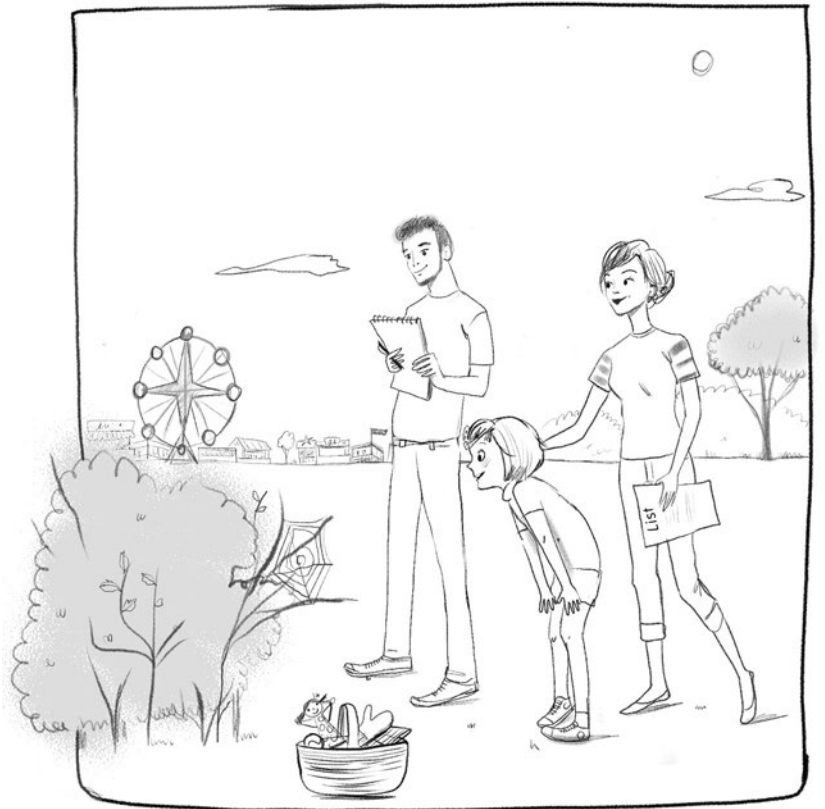

**High-Frequency Words Taught to Date**

a	brothers	eyes	head	maybe	people	sure	wash
about	brown	fall	hear	me	pictures	surprised	watch
above	buy	family	heard	minute	play	take	water
across	by	far	help	more	please	talk	we
after	call	father	her	most	pull	teacher	were
again	car	few	here	mother	pushed	the	what
all	carry	field	high	my	put	their	where
almost	caught	find	hold	myself	read	there	who
along	city	first	house	near	ready	these	why
always	cold	five	how	never	right	they	window
and	come	fly	I	new	said	think	with
animal	could	follow	idea	night	school	those	work
are	country	food	into	no	second	thought	world
around	covers	for	is	noise	see	three	would
away	cried	four	kinds	nothing	seven	to	write
baby	different	friend	know	now	shall	today	years
ball	do	friendship	large	of	she	together	yellow
be	does	full	laugh	off	should	too	you
bear	don't	funny	learning	old	show	took	young
beautiful	done	give	light	once	sing	toward	your
because	door	go	like	one	small	try	
been	down	goes	listen	only	soil	two	children
before	draw	good	little	open	some	under	next
began	earth	great	live	or	sometimes	until	
begins	eat	green	long	our	soon	use	
bird	eight	ground	look	out	sorry	very	
blue	enough	grow	loudly	over	starts	walk	
both	even	happy	loved	own	stories	want	
boy	every	have	make	paper	story	warms	
bring	everyone	he	many	party	studied	was	

**Decoding skills taught to date:** short *a*; short *i*; short *o*; short *u*; short *e*; CVC syllable pattern (closed)



# The Hunt Game

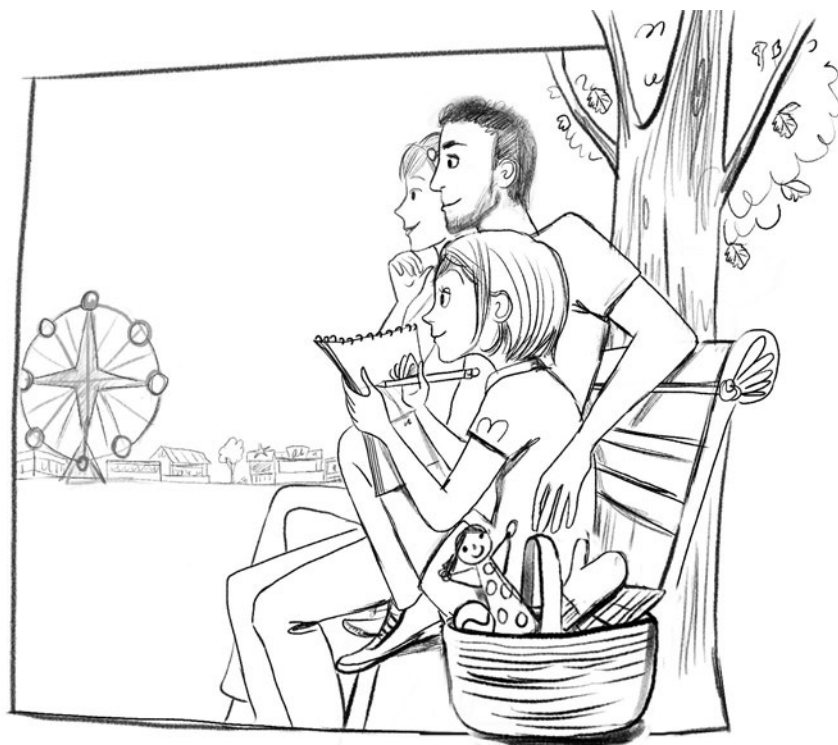

© Houghton Mifflin Harcourt Publishing Company

“The last thing is a sunset,” Mom said.

“Let me get it,” I said. “It can be a picture!”

I made a sunset. It went in the basket to end the hunt.



“Let’s play a fun game,” said Mom. “We will hunt in lots of spots to get things on this list.”

“Things we get go in this basket,” said Dad.



© Houghton Mifflin Harcourt Publishing Company



We got cotton napkins, mittens, and a puppet. Next, we got a big button.

“How can we get a cobweb?” I asked.  
“We cannot get it with our hands.”

“We can make a cobweb picture,” said Dad with a grin.

We got the cobweb. Then we got a bike helmet. But it was not on the list.



# Sunset on the Hill

## DECODABLE WORDS

**Target Skill:** CVC syllable pattern (closed syllables)

cobweb sudden yellow  
insects sunset

### Previously Taught Skills

and	end	it	saw	went
at	fast	log	set	with
Ben	fun	moth	snack	
big	good	on	Ted	
bird	had	peg	tent	
book	hill	Pop	then	
camp	hit	red	too	
day	in	sat	up	

SKILLS APPLIED IN WORDS IN STORY: short *a*, short *i*, short *o*, short *u*, short *e*; CVC syllable pattern (closed); consonants; short vowels; double final consonants *ll*; consonants *ck*; final blends; blends with *s*; final blend *nt*; final blend *nd*; digraph *th*; vowel combinations *ou*, *ow*; vowel combination *aw*; inflection *-s*; *r*-controlled vowel *ir*; long *a* (*ay*); vowel digraph /*oo*/ *oo*; vowel digraph/spelling pattern *oo*

## HIGH-FREQUENCY WORDS

a	all	the	to
about	of	they	was

© Houghton Mifflin Harcourt Publishing Company

CVC syllable pattern  
(closed syllables)

**BOOK 14**

# Sunset on the Hill



**High-Frequency Words Taught to Date**

a	brothers	eyes	head	maybe	people	sure	wash
about	brown	fall	hear	me	pictures	surprised	watch
above	buy	family	heard	minute	play	take	water
across	by	far	help	more	please	talk	we
after	call	father	her	most	pull	teacher	were
again	car	few	here	mother	pushed	the	what
all	carry	field	high	my	put	their	where
almost	caught	find	hold	myself	read	there	who
along	city	first	house	near	ready	these	why
always	cold	five	how	never	right	they	window
and	come	fly	I	new	said	think	with
animal	could	follow	idea	night	school	those	work
are	country	food	into	no	second	thought	world
around	covers	for	is	noise	see	three	would
away	cried	four	kinds	nothing	seven	to	write
baby	different	friend	know	now	shall	today	years
ball	do	friendship	large	of	she	together	yellow
be	does	full	laugh	off	should	too	you
bear	done	funny	learning	old	show	took	young
beautiful	don't	give	light	once	sing	toward	your
because	door	go	like	one	small	try	
been	down	goes	listen	only	soil	two	children
before	draw	good	little	open	some	under	next
began	earth	great	live	or	sometimes	until	
begins	eat	green	long	our	soon	use	
bird	eight	ground	look	out	sorry	very	
blue	enough	grow	loudly	over	starts	walk	
both	even	happy	loved	own	stories	want	
boy	every	have	make	paper	story	warms	
bring	everyone	he	many	party	studied	was	

**Decoding skills taught to date:** short *a*; short *i*; short *o*; short *u*; short *e*; CVC syllable pattern (closed syllables); consonants; short vowels; double final consonants *ll*; consonants *ck*; final blends; blends with *s*; final blend *nt*; final blend *nd*; digraph *th*; vowel combinations *ou*, *ow*; vowel combination *aw*; inflection *-s*; *r*-controlled vowel *ir*; long *a* (*ay*); vowel digraph /*oo*/ *oo*; vowel digraph/spelling pattern *oo*

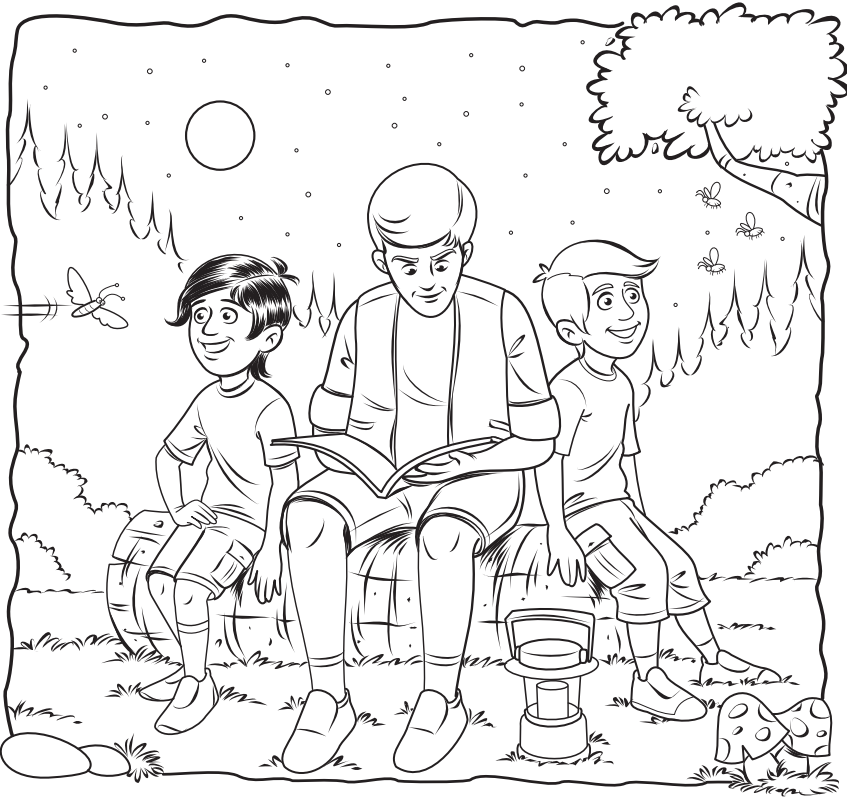

All of a sudden, Ted saw a big moth. Ben saw insects, too. It was fun to camp with Pop!

# Sunset on the Hill

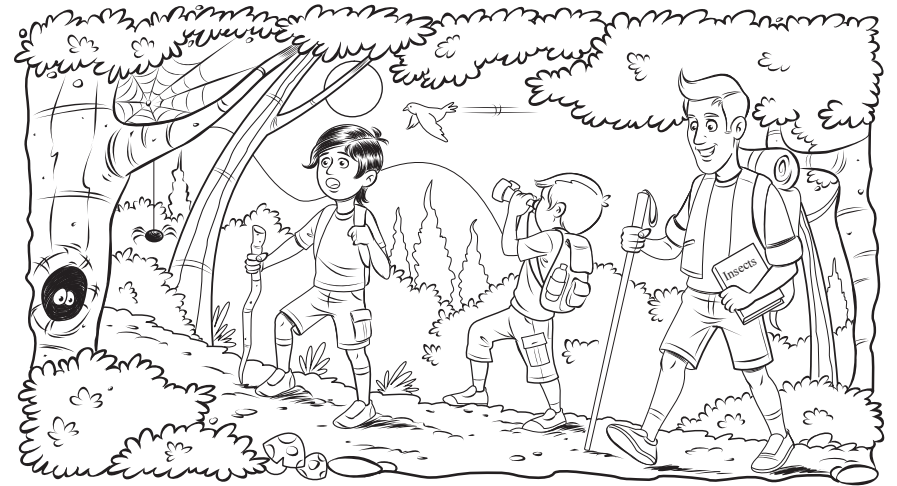

Ted, Ben, and Pop went to camp on the hill. They went up and up the big hill.

Ted saw a big cobweb. Ben saw a fast, yellow bird. Pop had a good book about insects.



Ted, Ben, and Pop set up camp at the end of the day. Ted hit the tent peg. Ben sat on a log and had a snack.

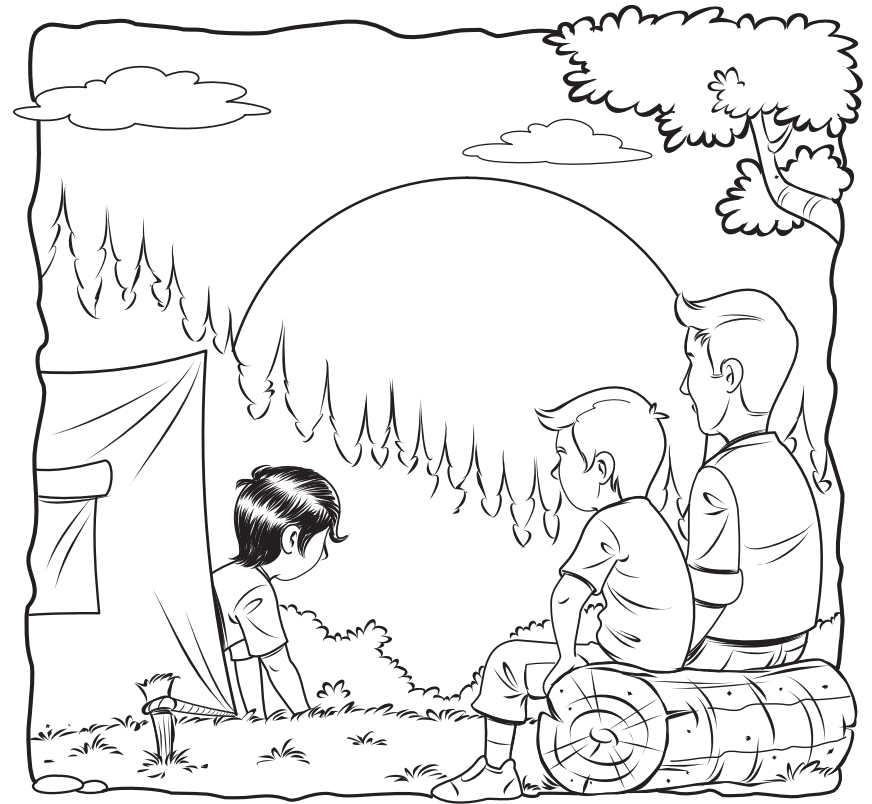

Then it was sunset. Ted was in the tent. Ben and Pop sat on the log. The sunset on the hill was red and yellow.

# Kate Has Frames

## DECODABLE WORDS

Target Skill: long a (CVCe)

ate	frames	Nate	wave
cake	Kate	plane	waves
Dave	made	takes	whale
frame	mane	wades	

## Previously Taught Skills

big	did	hits	Mom	this
can	fun	in	pals	win
Dad	has	is	run	with

SKILLS APPLIED IN WORDS IN STORY: short a; short i; short o; short u; short e; CVC syllable pattern (closed syllables); long a (CVCe); consonants; short vowels; r blends; l blends; digraph th; digraph wh; inflection -s

## HIGH-FREQUENCY WORDS

a	her	pictures	to
and	like	plays	what
are	looks	the	

© Houghton Mifflin Harcourt Publishing Company

long a (CVCe)

**BOOK 15**

# Kate Has Frames



**High-Frequency Words Taught to Date**

a	brothers	eyes	head	maybe	people	sure	wash
about	brown	fall	hear	me	pictures	surprised	watch
above	buy	family	heard	minute	play	take	water
across	by	far	help	more	please	talk	we
after	call	father	her	most	pull	teacher	were
again	car	few	here	mother	pushed	the	what
all	carry	field	high	my	put	their	where
almost	caught	find	hold	myself	read	there	who
along	city	first	house	near	ready	these	why
always	cold	five	how	never	right	they	window
and	come	fly	I	new	said	think	with
animal	could	follow	idea	night	school	those	work
are	country	food	into	no	second	thought	world
around	covers	for	is	noise	see	three	would
away	cried	four	kinds	nothing	seven	to	write
baby	different	friend	know	now	shall	today	years
ball	do	friendship	large	of	she	together	yellow
be	does	full	laugh	off	should	too	you
bear	done	funny	learning	old	show	took	young
beautiful	don't	give	light	once	sing	toward	your
because	door	go	like	one	small	try	
been	down	goes	listen	only	soil	two	children
before	draw	good	little	open	some	under	next
began	earth	great	live	or	sometimes	until	
begins	eat	green	long	our	soon	use	
bird	eight	ground	look	out	sorry	very	
blue	enough	grow	loudly	over	starts	walk	
both	even	happy	loved	own	stories	want	
boy	every	have	make	paper	story	warms	
bring	everyone	he	many	party	studied	was	

**Decoding skills taught to date:** short *a*; short *i*; short *o*; short *u*; short *e*; CVC syllable pattern (closed syllables); long *a* (CVCe); consonants; short vowels; *r* blends; *l* blends; digraph *th*; digraph *wh*; inflection *-s*



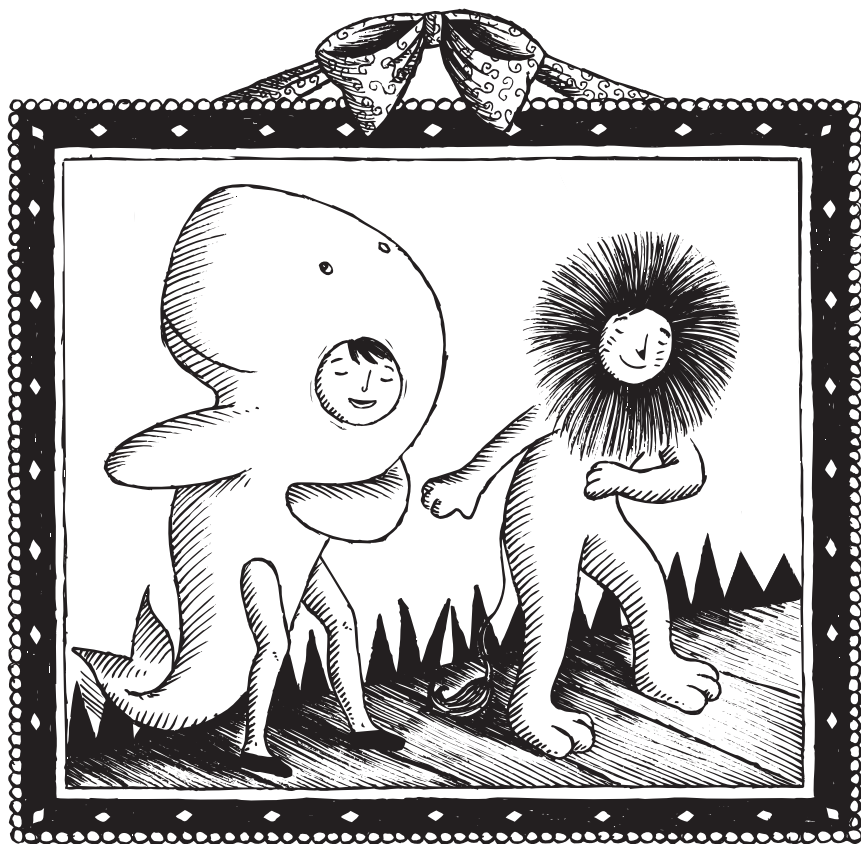

Mom made this frame. Kate plays a whale. Dave has a big mane. What is Dave?

# Kate Has Frames



Kate takes pictures. This frame has her pals, Dave and Nate. Dave can run. Nate can run. Did Dave win? Did Nate win?



What is in this frame? Kate wades with Dave in big waves. The waves are big, big, big. A big wave hits Kate. A big wave hits Dave. Kate has fun. Dave has fun.



Dad made this frame. Kate waves to Dad. Kate ate cake. The cake looks like a plane.



## Bake Sale

### DECODABLE WORDS

**Target Skill:** long *a* (CVCe)

bake	Dale	make	take
cake	Jake	Nate	
cakes	Lane	sale	

**Previously Taught Skills**

and	fun	nut	stop
at	get	sell	that
big	is	sick	this
can	mix	six	well
drops	Mom	stand	will

SKILLS APPLIED IN WORDS IN STORY: short *a*; short *e*; short *i*; short *u*; short *o*; CVC syllable pattern (closed syllables); long *a* (CVCe); consonants; short vowels; consonants *ck*; final blend *nd*; inflection *-s*; *r* blends; *s* blends; double consonants *ll*; digraph *th*

### HIGH-FREQUENCY WORDS

a	have	look	the	what
children	help	next	they	writes
give	I	said	to	

long *a* (CVCe)

**BOOK 16**

# Bake Sale

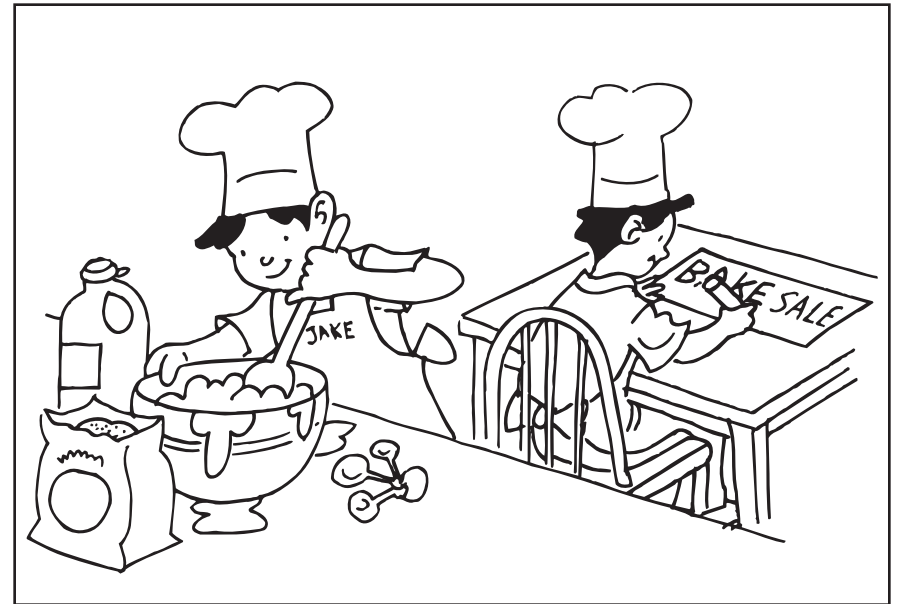

**High-Frequency Words Taught to Date**

a	brothers	eyes	head	maybe	people	sure	wash
about	brown	fall	hear	me	pictures	surprised	watch
above	buy	family	heard	minute	play	take	water
across	by	far	help	more	please	talk	we
after	call	father	her	most	pull	teacher	were
again	car	few	here	mother	pushed	the	what
all	carry	field	high	my	put	their	where
almost	caught	find	hold	myself	read	there	who
along	city	first	house	near	ready	these	why
always	cold	five	how	never	right	they	window
and	come	fly	I	new	said	think	with
animal	could	follow	idea	night	school	those	work
are	country	food	into	no	second	thought	world
around	covers	for	is	noise	see	three	would
away	cried	four	kinds	nothing	seven	to	write
baby	different	friend	know	now	shall	today	years
ball	do	friendship	large	of	she	together	yellow
be	does	full	laugh	off	should	too	you
bear	done	funny	learning	old	show	took	young
beautiful	don't	give	light	once	sing	toward	your
because	door	go	like	one	small	try	
been	down	goes	listen	only	soil	two	children
before	draw	good	little	open	some	under	next
began	earth	great	live	or	sometimes	until	
begins	eat	green	long	our	soon	use	
bird	eight	ground	look	out	sorry	very	
blue	enough	grow	loudly	over	starts	walk	
both	even	happy	loved	own	stories	want	
boy	every	have	make	paper	story	warms	
bring	everyone	he	many	party	studied	was	

**Decoding skills taught to date:** short *a*; short *i*; short *o*; short *u*; short *e*; CVC syllable pattern (closed syllables); long *a* (CVCe); consonants; short vowels; consonants *ck*; final blend *nd*; inflection *-s*; *r* blends; *s* blends; double consonants *ll*; digraph *th*



The bake sale is fun! Children stop at the bake sale.

"I will take that big cake!" said Nate.

"I will take six nut drops," said Lane.

# Bake Sale



Jake and Dale can bake. What will Jake and Dale bake? They will bake big cakes. Mom will help Jake and Dale bake cakes. Jake can mix and mix.



What will Dale and Jake bake? Look at what Dale and Jake can make!

They can make nut drops! Dale and Jake can bake cakes and nut drops.

Dale and Jake will have a bake sale.



They make a stand. Next, Dale writes Bake Sale. Jake, Dale, and Mom will sell cakes and nut drops at the bake sale. Dale and Jake will give what they make to sick children. This will help sick children get well.

## Win a Bike

### DECODABLE WORDS

Target Skill: long *i* (CVCe)

bike	ice	Mike	ride	twine
fine	kite	mile	smiled	wide
hike	line	prize	time	

### Previously Taught Skills

added	frame	I	sticks	win
and	get	if	taped	with
asks	got	it	tells	won
at	had	long	test	yes
best	he	made	then	you
can	hill	make	top	
cream	his	makes	up	
far	home	Mom	way	
for	hot	next	went	

SKILLS APPLIED IN WORDS IN STORY: short *a*; short *i*; short *o*; short *u*; short *e*; long *a* (CVCe); long *i* (CVCe); consonants; short vowels; inflection -s; double final consonants; /k/ spelled *ck*; initial and final blends; digraph *th*; /s/ spelled *c*; long *o* (CVCe); long *e* spelled *ea*; long *a* spelled *ay*; /ōō/ spelled *ou*; *r*-controlled vowels; base words and endings -ed; long *i* spelled *i*; long *e* spelled *e*

### HIGH-FREQUENCY WORDS

a	of	the	to	was
about	paper	they	very	
all	said	this	walk	

# Win a Bike



**High-Frequency Words Taught to Date**

a	brothers	eyes	head	maybe	people	sure	wash
about	brown	fall	hear	me	pictures	surprised	watch
above	buy	family	heard	minute	play	take	water
across	by	far	help	more	please	talk	we
after	call	father	her	most	pull	teacher	were
again	car	few	here	mother	pushed	the	what
all	carry	field	high	my	put	their	where
almost	caught	find	hold	myself	read	there	who
along	city	first	house	near	ready	these	why
always	cold	five	how	never	right	they	window
and	come	fly	I	new	said	think	with
animal	could	follow	idea	night	school	those	work
are	country	food	into	no	second	thought	world
around	covers	for	is	noise	see	three	would
away	cried	four	kinds	nothing	seven	to	write
baby	different	friend	know	now	shall	today	years
ball	do	friendship	large	of	she	together	yellow
be	does	full	laugh	off	should	too	you
bear	done	funny	learning	old	show	took	young
beautiful	don't	give	light	once	sing	toward	your
because	door	go	like	one	small	try	
been	down	goes	listen	only	soil	two	children
before	draw	good	little	open	some	under	next
began	earth	great	live	or	sometimes	until	other
begins	eat	green	long	our	soon	use	this
bird	eight	ground	look	out	sorry	very	
blue	enough	grow	loudly	over	starts	walk	
both	even	happy	loved	own	stories	want	
boy	every	have	make	paper	story	warms	
bring	everyone	he	many	party	studied	was	

**Decoding skills taught to date:** short *a*; short *i*; short *o*; short *u*; short *e*; closed syllables; long *a* (CVC*e*); long *i* (CVC*e*); consonants; short vowels; inflection -s; double final consonants; /k/ spelled *ck*; initial and final blends; digraph *th*; /s/ spelled *c*; long *o* (CVC*e*); long *e* spelled *ea*; long *a* spelled *ay*; /ō/ spelled *ou*; *r*-controlled vowels; base words and endings -*ed*; long *i* spelled *i*; long *e* spelled *e*

# Win a Bike

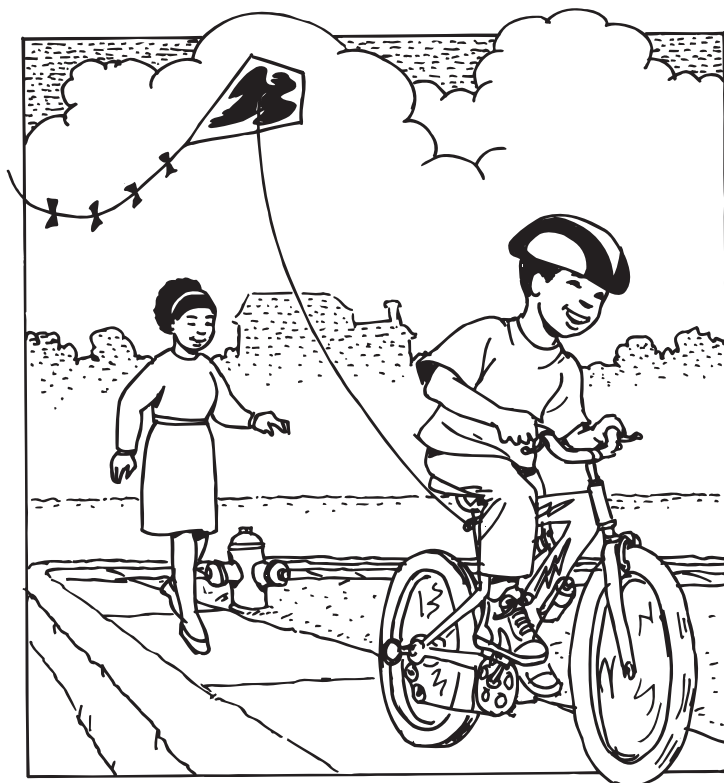

© Houghton Mifflin Harcourt Publishing Company

Then it was time for Mike to test his kite. Mike had the best kite! Mike won the top prize. Mike got to ride his bike home. Ride, Mike, ride! Ride all the way home!

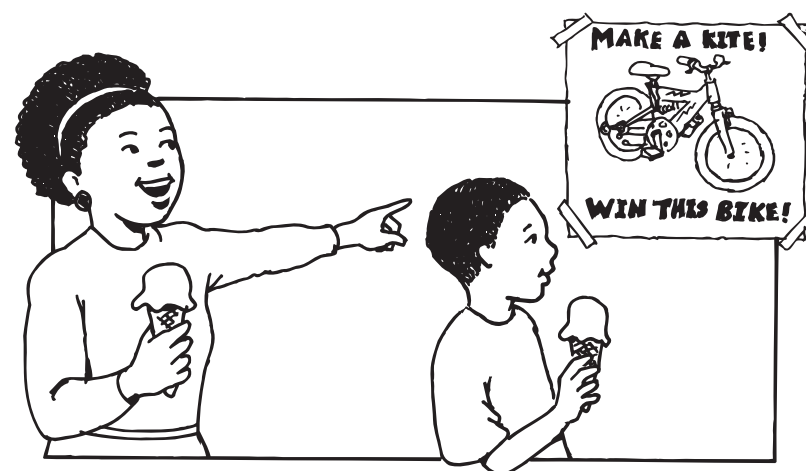

Mike and Mom had to walk very far to get ice cream. They had to hike a mile up hill. Mike was hot, hot, hot. Mom was hot, hot, hot.

Mom tells Mike about a fine prize. "I can win a bike?" asks Mike. "Yes, you can!" Mom tells Mike.



Mike can win a bike if he makes the best kite.

Mike smiled at Mom. Mike said, "I can make the best kite. I can win the top prize. I can win the bike."

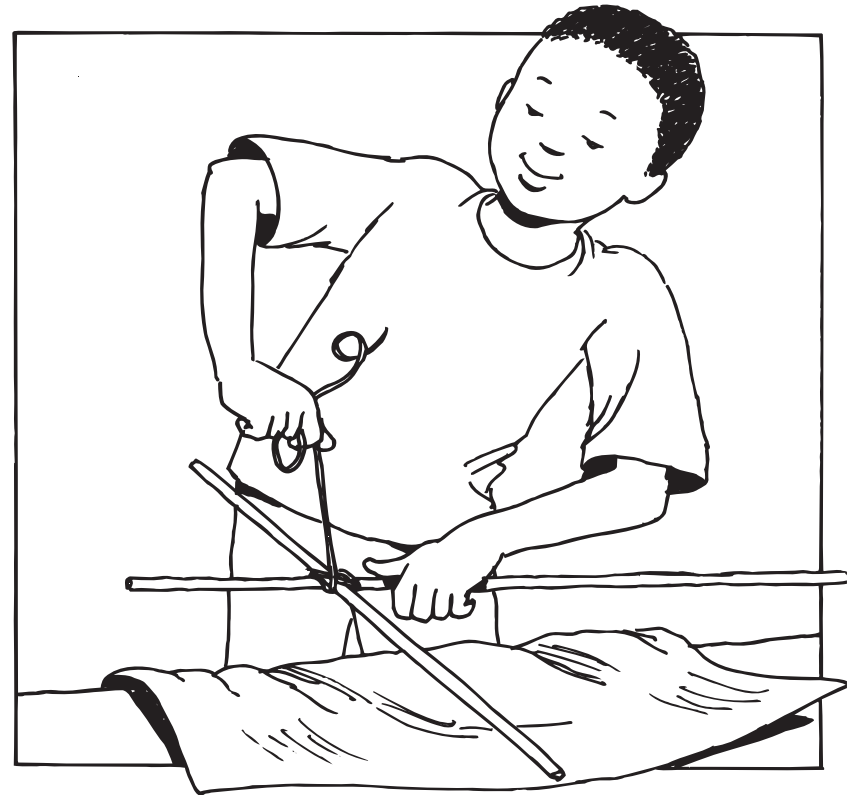

Mike went home to make his kite. Mike made a wide frame with sticks and twine. Mike taped paper to the wide frame. Next, Mike added a long, long, line of twine.



## Sam and Bev

### DECODABLE WORDS

Target Skill: long *i* (CVCe)

bike	five	kite	ride	while
bikes	hide	like	riding	wide
bite	hides	likes	smiles	
fine	hike	nice	time	

Previously Taught Skills

a	fly	no	see	will
and	for	not	seek	with
asks	get	now	she	yelled
at	go	on	spend	yells
Bev	grass	pal	spot	yes
can	her	pals	steps	you
chat	hi	play	stop	
chose	I	rest	tells	
counts	in	rode	to	
eat	next	Sam	waiting	

SKILLS APPLIED IN WORDS IN STORY: short *a*; short *i*; short *o*; short *e*; long *i* (CVCe); consonants; short vowels; inflection *-s*; base words and endings *-ing*, *-ed*; initial and final blends; long *o* (CVCe); long *o* spelled *o*; long *i* spelled *i*, *y*; long *e* spelled *e*, *ee*, *ea*; long *a* spelled *ai*, *ay*; *r*-controlled vowels; /ōō/ spelled *ou*; double final consonants; digraphs; /s/ spelled *c*; /ou/ spelled *ow*, *ou*

### HIGH-FREQUENCY WORDS

a	have	their	want	would
are	said	they	was	
do	the	to	what	

long *i* (CVCe)

**BOOK 18**

# Sam and Bev

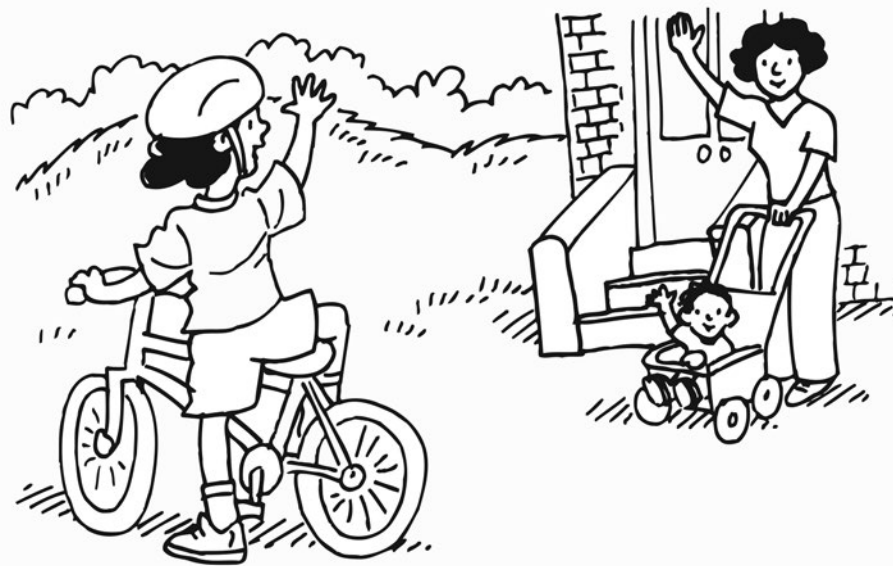

**High-Frequency Words Taught to Date**

a	brothers	eyes	head	maybe	people	sure	wash
about	brown	fall	hear	me	pictures	surprised	watch
above	buy	family	heard	minute	play	take	water
across	by	far	help	more	please	talk	we
after	call	father	her	most	pull	teacher	were
again	car	few	here	mother	pushed	the	what
all	carry	field	high	my	put	their	where
almost	caught	find	hold	myself	read	there	who
along	city	first	house	near	ready	these	why
always	cold	five	how	never	right	they	window
and	come	fly	I	new	said	think	with
animal	could	follow	idea	night	school	those	work
are	country	food	into	no	second	thought	world
around	covers	for	is	noise	see	three	would
away	cried	four	kinds	nothing	seven	to	write
baby	different	friend	know	now	shall	today	years
ball	do	friendship	large	of	she	together	yellow
be	does	full	laugh	off	should	too	you
bear	done	funny	learning	old	show	took	young
beautiful	don't	give	light	once	sing	toward	your
because	door	go	like	one	small	try	
been	down	goes	listen	only	soil	two	children
before	draw	good	little	open	some	under	next
began	earth	great	live	or	sometimes	until	other
begins	eat	green	long	our	soon	use	this
bird	eight	ground	look	out	sorry	very	
blue	enough	grow	loudly	over	starts	walk	
both	even	happy	loved	own	stories	want	
boy	every	have	make	paper	story	warms	
bring	everyone	he	many	party	studied	was	

**Decoding skills taught to date:** short *a*; short *i*; short *o*; short *u*; short *e*; closed syllables; long *a* (CVCe); long *i* (CVCe); consonants; short vowels; inflection *-s*; base words and endings *-ing*, *-ed*; initial and final blends; long *o* (CVCe); long *o* spelled *o*; long *i* spelled *i*, *y*; long *e* spelled *e*, *ee*, *ea*; long *a* spelled *ai*, *ay*; *r*-controlled vowels; /ōō/ spelled *ou*; double final consonants; digraphs; /s/ spelled *c*; /ou/ spelled *ow*, *ou*



Sam and Bev rest on the grass and chat. What will they do next time? Will they go on a hike? Will they get a bite to eat? Will they fly a kite? Sam and Bev are pals. Sam likes to spend time with Bev. Bev likes to spend time with Sam.

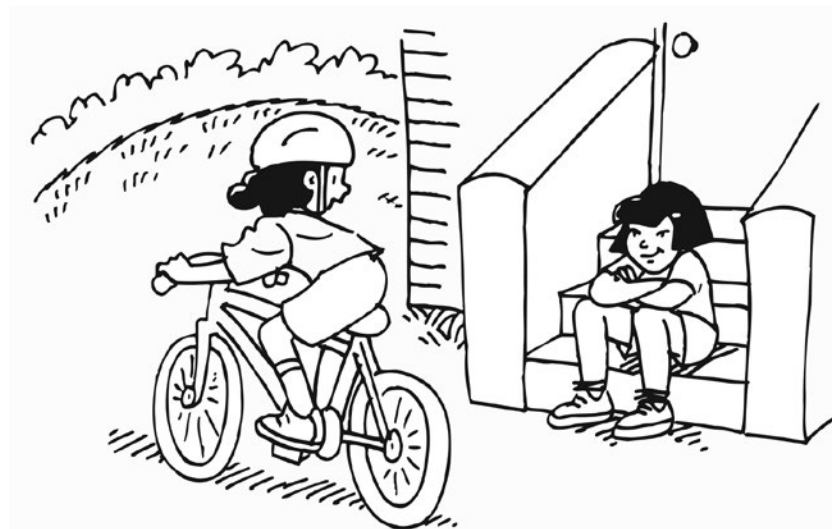

Sam rode her bike to see her pal Bev. Bev was waiting for Sam on her wide steps.

“Hi, Bev!” said Sam. “Would you like to go for a bike ride?”

“Yes!” yelled Bev. “I like to ride with you!”

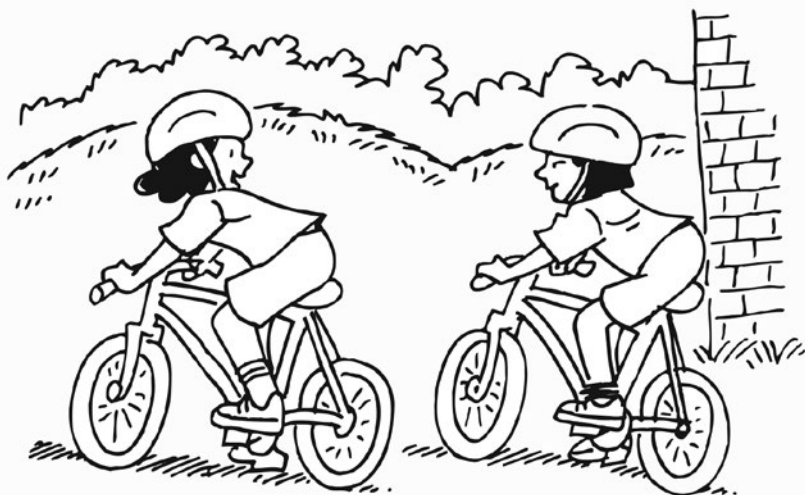

Sam and Bev ride their bikes for a while. They have a nice time riding their bikes. Sam smiles at Bev. Bev smiles at Sam.

“Do you want to stop, Bev?” asks Sam.

“Yes,” Bev tells Sam. “What do you want to do now?”



Sam and Bev play hide and seek. Sam counts to five. Bev hides in a nice spot while Sam counts.

“Five!” yells Sam.

Can Sam see Bev? No, she can not. Bev chose a fine spot!

# Cal Likes Corn

## DECODABLE WORDS

Target Skill: /k/ spelled c

Cal	cob	cut
can	corn	cuts

## Previously Taught Skills

and	fast	in	Mom	puts
at	for	is	napkin	ripe
big	fun	it	next	rubs
bite	get	just	not	team
clean	gets	like	on	time
cleans	has	likes	pick	wipes
Dad	helps	lot	picked	
eat	hot	make	pot	

SKILLS APPLIED IN WORDS IN STORY: short a; short e; short i; short o; short u; long a (CVCe); long i (CVCe); closed syllables; /k/ spelled c; consonants; short vowels; inflection -s; r-controlled vowels; /z/ spelled s; /k/ spelled ck; initial and final blends; long e spelled ea; base words and -ed endings

## HIGH-FREQUENCY WORDS

a	have	one	they	when
does	no	she	to	with
good	of	the	wants	

© Houghton Mifflin Harcourt Publishing Company

/k/ spelled c

**BOOK 19**

# Cal Likes Corn



**High-Frequency Words Taught to Date**

a	brothers	eyes	head	maybe	people	sure	wash
about	brown	fall	hear	me	pictures	surprised	watch
above	buy	family	heard	minute	play	take	water
across	by	far	help	more	please	talk	we
after	call	father	her	most	pull	teacher	were
again	car	few	here	mother	pushed	the	what
all	carry	field	high	my	put	their	where
almost	caught	find	hold	myself	read	there	who
along	city	first	house	near	ready	these	why
always	cold	five	how	never	right	they	window
and	come	fly	I	new	said	think	with
animal	could	follow	idea	night	school	those	work
are	country	food	into	no	second	thought	world
around	covers	for	is	noise	see	three	would
away	cried	four	kinds	nothing	seven	to	write
baby	different	friend	know	now	shall	today	years
ball	do	friendship	large	of	she	together	yellow
be	does	full	laugh	off	should	too	you
bear	done	funny	learning	old	show	took	young
beautiful	don't	give	light	once	sing	toward	your
because	door	go	like	one	small	try	
been	down	goes	listen	only	soil	two	children
before	draw	good	little	open	some	under	next
began	earth	great	live	or	sometimes	until	other
begins	eat	green	long	our	soon	use	this
bird	eight	ground	look	out	sorry	very	
blue	enough	grow	loudly	over	starts	walk	
both	even	happy	loved	own	stories	want	
boy	every	have	make	paper	story	warms	
bring	everyone	he	many	party	studied	was	

**Decoding skills taught to date:** short *a*; short *i*; short *o*; short *u*; short *e*; closed syllables; long *a* (CVC*a*); long *i* (CVC*i*); /k/ spelled *c*; consonants; short vowels; inflection -*s*; *r*-controlled vowels; /z/ spelled *s*; /k/ spelled *ck*; initial and final blends; long *e* spelled *ea*; base words and -*ed* endings



# Cal Likes Corn



The corn is big and ripe. It is time to pick it. Mom and Dad have a lot of corn to pick and no time to pick it. Cal helps Mom and Dad pick the corn. Cal, Mom, and Dad make a good team! Cal has fun when she helps Mom and Dad.



The corn is hot, hot, hot. It is time to eat it. Cal does not cut the corn. Cal likes to eat corn on the cob. Cal can bite the corn. Cal, Mom, and Dad like to eat the corn they just picked.





It is time to clean the corn. Cal cleans the corn she picked. She rubs it and wipes it with a napkin. Mom cuts the corn for Cal. Cal wipes and Mom cuts. Cal and Mom make a good team!



Mom has a big pot. Cal puts one corn in at a time. Next, the big pot gets hot. Mom helps Cal with the hot pot. Cal wants the corn to get hot fast.

# Cal and Cam

## DECODABLE WORDS

Target Skill: /k/ Spelled c

Cal	can	caps
Cam	cap	cop

## Previously Taught Skills

a	five	like	play	which
and	fun	makes	sad	will
as	has	mom	tells	yells
asks	his	not	ten	yes
at	I	pal	time	
best	is	pals	wait	
but	it	plan	well	

SKILLS APPLIED IN WORDS IN STORY: short a; short i; short o; short u; short e; long a (CVCe); long i (CVCe); /k/ spelled c; consonants; short vowels; initial and final blends; inflection -s; /z/ spelled s; long a spelled ay, ai; double final consonants; long i spelled i; digraphs

## HIGH-FREQUENCY WORDS

a	do	house	then	you
all	does	now	they	
are	go	over	to	
call	have	see	want	
come	he	the	with	

© Houghton Mifflin Harcourt Publishing Company

/k/ Spelled c

**BOOK 20**

# Cal and Cam



**High-Frequency Words Taught to Date**

a	brothers	eyes	head	maybe	people	sure	wash
about	brown	fall	hear	me	pictures	surprised	watch
above	buy	family	heard	minute	play	take	water
across	by	far	help	more	please	talk	we
after	call	father	her	most	pull	teacher	were
again	car	few	here	mother	pushed	the	what
all	carry	field	high	my	put	their	where
almost	caught	find	hold	myself	read	there	who
along	city	first	house	near	ready	these	why
always	cold	five	how	never	right	they	window
and	come	fly	I	new	said	think	with
animal	could	follow	idea	night	school	those	work
are	country	food	into	no	second	thought	world
around	covers	for	is	noise	see	three	would
away	cried	four	kinds	nothing	seven	to	write
baby	different	friend	know	now	shall	today	years
ball	do	friendship	large	of	she	together	yellow
be	does	full	laugh	off	should	too	you
bear	done	funny	learning	old	show	took	young
beautiful	don't	give	light	once	sing	toward	your
because	door	go	like	one	small	try	
been	down	goes	listen	only	soil	two	children
before	draw	good	little	open	some	under	next
began	earth	great	live	or	sometimes	until	other
begins	eat	green	long	our	soon	use	this
bird	eight	ground	look	out	sorry	very	
blue	enough	grow	loudly	over	starts	walk	
both	even	happy	loved	own	stories	want	
boy	every	have	make	paper	story	warms	
bring	everyone	he	many	party	studied	was	

**Decoding skills taught to date:** short *a*; short *i*; short *o*; short *u*; short *e*; closed syllables; long *a* (CVCe); long *i* (CVCe); /k/ spelled *c*; consonants; short vowels; initial and final blends; inflection *-s*; /z/ spelled *s*; long *a* spelled *ay*, *ai*; double final consonants; long *i* spelled *ie*; digraphs



It is five and Cal has to go. Cam does not want Cal to go but he is not sad. Cam and Cal have a plan! Cam will go with Cal and his mom. They will play at his house now. Cam and Cal are best pals!

## Cal and Cam



Cam makes a call to his best pal Cal. "Cal, can you play at ten?" asks Cam. "Yes!" Cal tells Cam. "I will go over then."

"See you at ten," Cam tells Cal. "I can not wait!"



Cal and his mom come at ten.

"See you at five, Mom," yells Cal.

Cal and Cam are best pals. Cal and Cam like to play. Cal and Cam have fun all the time.

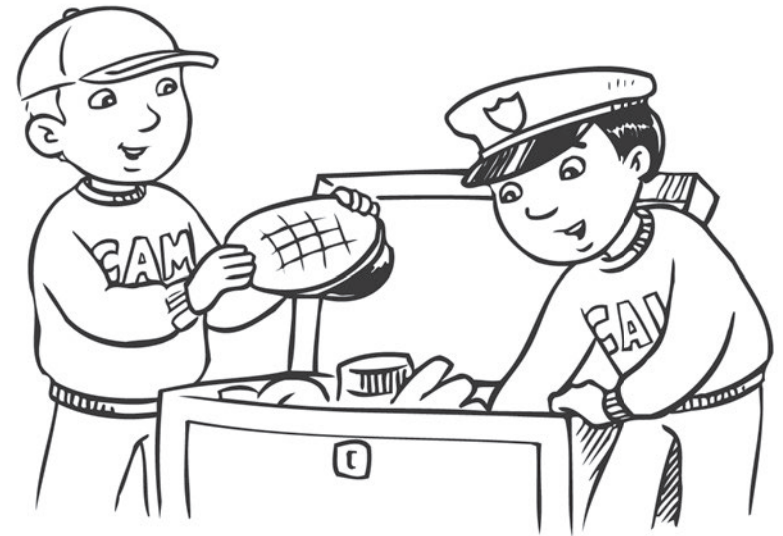

Cal and Cam play with caps.

"Which cap do you like best Cam?" asks Cal.

"I like the cop cap," Cal tells Cam.

"Which cap do you like, Cam?"

"I like the cop cap as well," Cam tells Cal.

## Grace Has Pet Mice

### DECODABLE WORDS

Target Skill: /s/ spelled c

Grace	mice	place	Prince	space
Lace	nice	price	race	

### Previously Taught Skills

and	end	her	likes	safe
at	food	in	must	sets
big	for	is	names	store
box	get	it	pet	up
can	gets	let	prize	
cannot	has	like	run	

SKILLS APPLIED IN WORDS IN STORY: short a; short e; short i; short o; short u; closed syllables; long a (CVCe); long i (CVCe); /k/ spelled c; /s/ spelled c; consonants; short vowels; initial and final blends; /z/ spelled s; inflection -s; r-controlled vowels

### HIGH-FREQUENCY WORDS

a	food	of	the	with
are	go	off	to	
buy	good	play	will	

# Grace Has Pet Mice

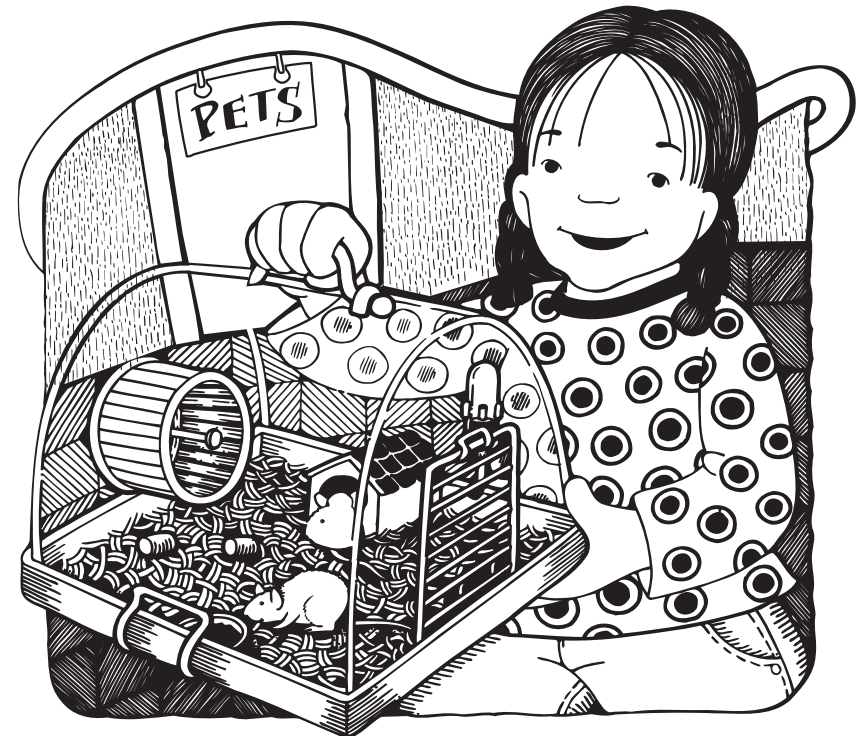



**High-Frequency Words Taught to Date**

a	brothers	eyes	head	maybe	people	sure	wash
about	brown	fall	hear	me	pictures	surprised	watch
above	buy	family	heard	minute	play	take	water
across	by	far	help	more	please	talk	we
after	call	father	her	most	pull	teacher	were
again	car	few	here	mother	pushed	the	what
all	carry	field	high	my	put	their	where
almost	caught	find	hold	myself	read	there	who
along	city	first	house	near	ready	these	why
always	cold	five	how	never	right	they	window
and	come	fly	I	new	said	think	with
animal	could	follow	idea	night	school	those	work
are	country	food	into	no	second	thought	world
around	covers	for	is	noise	see	three	would
away	cried	four	kinds	nothing	seven	to	write
baby	different	friend	know	now	shall	today	years
ball	do	friendship	large	of	she	together	yellow
be	does	full	laugh	off	should	too	you
bear	done	funny	learning	old	show	took	young
beautiful	don't	give	light	once	sing	toward	your
because	door	go	like	one	small	try	
been	down	goes	listen	only	soil	two	children
before	draw	good	little	open	some	under	next
began	earth	great	live	or	sometimes	until	other
begins	eat	green	long	our	soon	use	this
bird	eight	ground	look	out	sorry	very	
blue	enough	grow	loudly	over	starts	walk	
both	even	happy	loved	own	stories	want	
boy	every	have	make	paper	story	warms	
bring	everyone	he	many	party	studied	was	

**Decoding skills taught to date:** short *a*; short *i*; short *o*; short *u*; short *e*; closed syllables; long *a* (CVC*a*); long *i* (CVC*i*); /k/ spelled *c*; /s/ spelled *c*; consonants; short vowels; initial and final blends; /z/ spelled *s*; inflection -*s*; *r*-controlled vowels



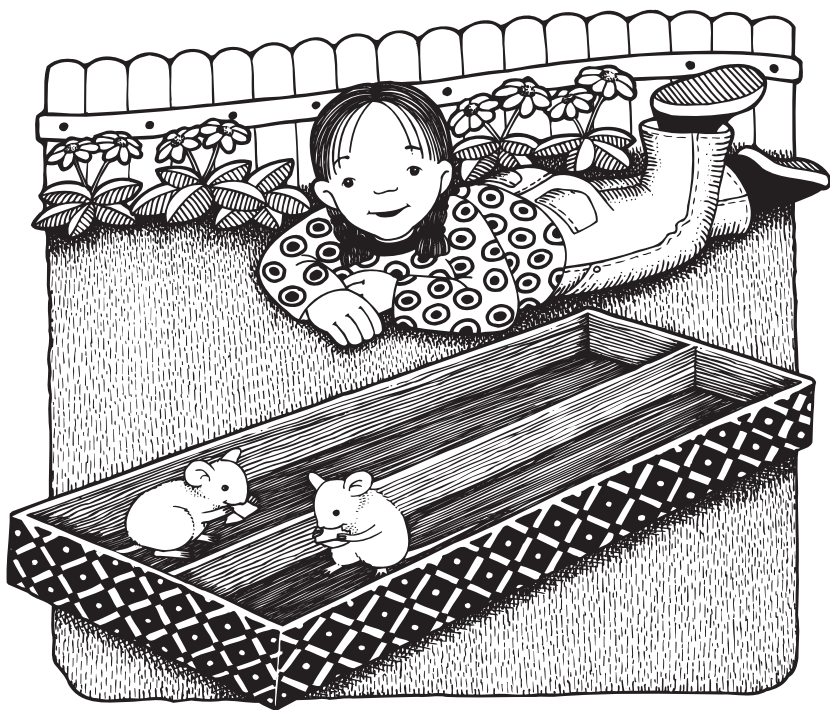

Grace sets up a space for her mice to run a race. Run, run, run, Lace! Run, run, run, Prince! At the end of the race, the mice get a prize. Grace has nice pet mice.

# Grace Has Pet Mice

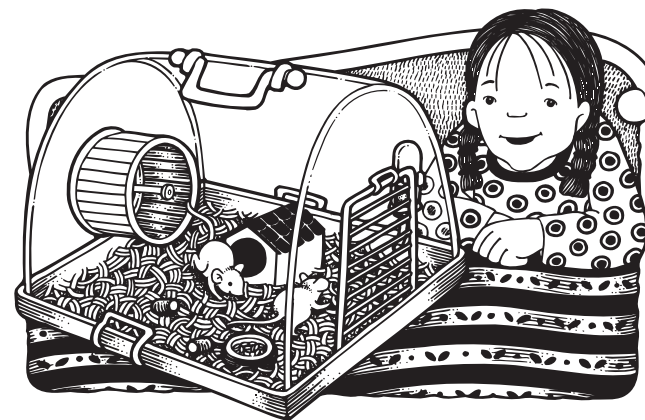

Grace has nice pet mice. The names of her mice are Lace and Prince. The mice can run in a big space. Run, run, run, Lace! Run, run, run, Prince!



Grace can go to the pet store to get food for her mice. Grace will get the food her mice like. Grace gets the big box. It is the food her mice like. Grace can buy it at a good price.



Grace likes to play with her mice. Grace must play with her mice in a nice, safe place. Mice like to run, run, run. Grace cannot let her mice run off.

# One Cent

## DECODABLE WORDS

Target Skill: /s/ spelled c

cent          cents          Joyce          Lance          nice

## Previously Taught Skills

and	Dad	had	lots	than
asks	did	has	more	that
but	dimes	he	not	them
can	find	her	or	toy
cannot	fine	hot	sad	we
cap	five	if	she	will
costs	for	is	still	with
cub	get	it	tells	

SKILLS APPLIED IN WORDS IN STORY: short a; short i; short o; short u; short e; closed syllables; long i (CVCe); /k/ spelled c; /s/ spelled c; consonants; short vowels; initial and final blends; /oi/ spelled oy; /z/ spelled s; digraphs; double final consonants; r-controlled vowels; long e spelled e

## HIGH-FREQUENCY WORDS

a	drinks	of	see
could	I	one	the
do	know	only	thing
drink	no	out	what

© Houghton Mifflin Harcourt Publishing Company

/s/ spelled c

**BOOK 22**

# One Cent

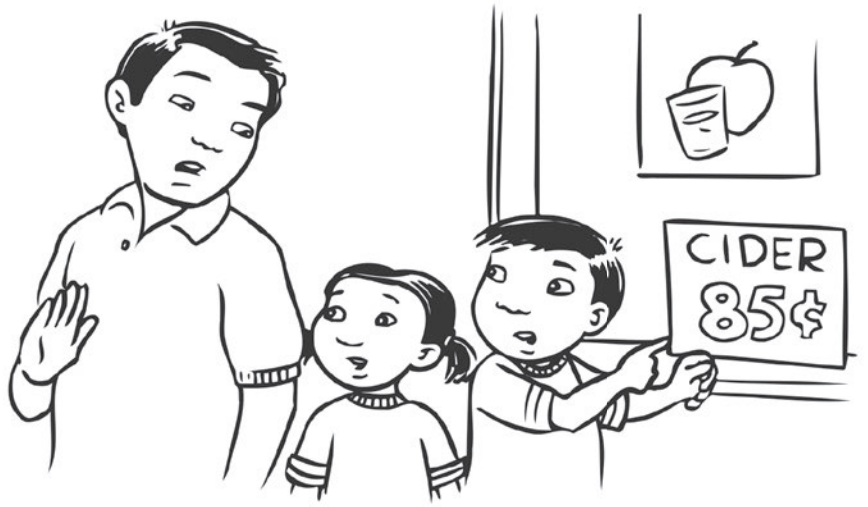

**High-Frequency Words Taught to Date**

a	brothers	eyes	head	maybe	people	sure	wash
about	brown	fall	hear	me	pictures	surprised	watch
above	buy	family	heard	minute	play	take	water
across	by	far	help	more	please	talk	we
after	call	father	her	most	pull	teacher	were
again	car	few	here	mother	pushed	the	what
all	carry	field	high	my	put	their	where
almost	caught	find	hold	myself	read	there	who
along	city	first	house	near	ready	these	why
always	cold	five	how	never	right	they	window
and	come	fly	I	new	said	think	with
animal	could	follow	idea	night	school	those	work
are	country	food	into	no	second	thought	world
around	covers	for	is	noise	see	three	would
away	cried	four	kinds	nothing	seven	to	write
baby	different	friend	know	now	shall	today	years
ball	do	friendship	large	of	she	together	yellow
be	does	full	laugh	off	should	too	you
bear	done	funny	learning	old	show	took	young
beautiful	don't	give	light	once	sing	toward	your
because	door	go	like	one	small	try	
been	down	goes	listen	only	soil	two	children
before	draw	good	little	open	some	under	next
began	earth	great	live	or	sometimes	until	other
begins	eat	green	long	our	soon	use	this
bird	eight	ground	look	out	sorry	very	
blue	enough	grow	loudly	over	starts	walk	
both	even	happy	loved	own	stories	want	
boy	every	have	make	paper	story	warms	
bring	everyone	he	many	party	studied	was	

**Decoding skills taught to date:** short *a*; short *i*; short *o*; short *u*; short *e*; closed syllables; long *a* (CVCe); long *i* (CVCe); /k/ spelled *c*; /s/ spelled *c*; consonants; short vowels; initial and final blends; /oi/ spelled *oy*; /z/ spelled *s*; digraphs; double final consonants; *r*-controlled vowels; long *e* spelled *e*

# One Cent



Joyce has one cent. Dad and Lance can see the cent.

"Dad, what can I get with one cent?" asks Joyce.

"I do not know, but we will find out!" Dad tells Joyce.



Joyce did not get a nice cap or a fine toy cub. Joyce is sad and hot. Dad tells Joyce and Lance that he will get them a drink. He has lots of cents for the drinks. Joyce did get a nice thing! It is a fine drink! Joyce still has one cent. What can Joyce do with her cent?





Can Joyce get a nice cap? No, Joyce cannot get a nice cap. Joyce only has one cent. The cap costs more than one cent. If Joyce had five dimes, she could get the nice cap. Will Joyce get a nice thing?

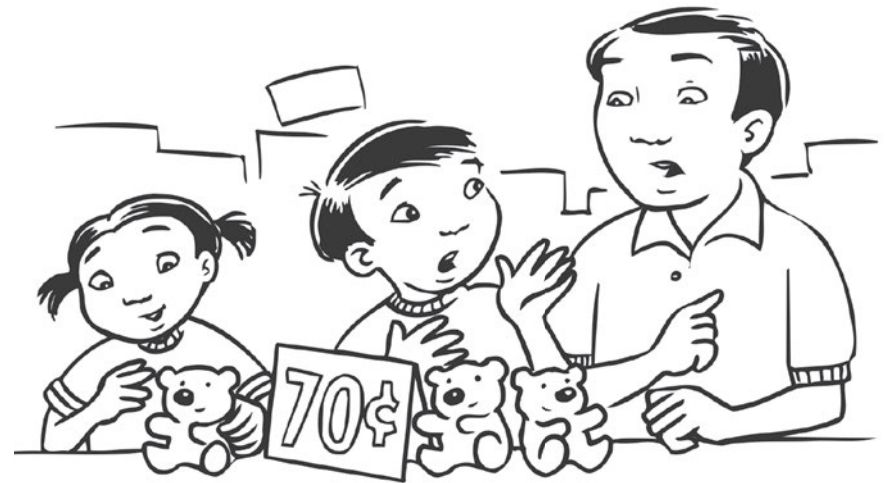

Can Joyce get a fine toy cub? No, Joyce cannot get a fine toy cub. Joyce only has one cent and the toy cub costs more than that. If Joyce had lots of cents, she could get the fine toy. Will Joyce get a fine thing?

## Rose Got a Note

### DECODABLE WORDS

Target Skill: long o (CVCe)

close	home	notes	Rose	wrote
cove	note	robe	stone	
hole	notebook	rode	woke	

### Previously Taught Skills

and	fun	is	nice	then
at	gave	it	on	this
be	go	jake	pal	time
big	got	like	pen	up
bug	had	look	picked	us
bugs	her	lots	put	we
can	his	me	take	with
for	in	mom	takes	write

SKILLS APPLIED IN WORDS IN STORY: short *a*; short *i*; short *o*; short *u*; short *e*; closed syllables; long *a* (CVCe); long *i* (CVCe); /k/ spelled *c*; /s/ spelled *c*; long *o* (CVCe); consonants; short vowels; /z/ spelled *s*; *r*-controlled vowels; digraphs; long *o* spelled *o*; long *e* spelled *e*; /ōō/ spelled *oo*; compound words; initial and final blends; inflection *-s*; base words and *-ed* endings; /k/ spelled *ck*

### HIGH-FREQUENCY WORDS

a	I	see	too	will
about	my	tells	under	you
bring	of	the	want	your
draw	said	to	what	

# Rose Got a Note





**High-Frequency Words Taught to Date**

a	brothers	eyes	head	maybe	people	sure	wash
about	brown	fall	hear	me	pictures	surprised	watch
above	buy	family	heard	minute	play	take	water
across	by	far	help	more	please	talk	we
after	call	father	her	most	pull	teacher	were
again	car	few	here	mother	pushed	the	what
all	carry	field	high	my	put	their	where
almost	caught	find	hold	myself	read	there	who
along	city	first	house	near	ready	these	why
always	cold	five	how	never	right	they	window
and	come	fly	I	new	said	think	with
animal	could	follow	idea	night	school	those	work
are	country	food	into	no	second	thought	world
around	covers	for	is	noise	see	three	would
away	cried	four	kinds	nothing	seven	to	write
baby	different	friend	know	now	shall	today	years
ball	do	friendship	large	of	she	together	yellow
be	does	full	laugh	off	should	too	you
bear	done	funny	learning	old	show	took	young
beautiful	don't	give	light	once	sing	toward	your
because	door	go	like	one	small	try	
been	down	goes	listen	only	soil	two	cheer
before	draw	good	little	open	some	under	children
began	earth	great	live	or	sometimes	until	hello
begins	eat	green	long	our	soon	use	hundred
bird	eight	ground	look	out	sorry	very	mind
blue	enough	grow	loudly	over	starts	walk	next
both	even	happy	loved	own	stories	want	other
boy	every	have	make	paper	story	warms	this
bring	everyone	he	many	party	studied	was	

**Decoding skills taught to date:** short *a*; short *i*; short *o*; short *u*; short *e*; closed syllables; long *a* (CVC $\hat{a}$ ); long *i* (CVC $\hat{i}$ ); /k/ spelled *c*; /s/ spelled *c*; long *o* (CVC $\hat{o}$ ); consonants; short vowels; /z/ spelled *s*; *r*-controlled vowels; digraphs; long *o* spelled *o*; long *e* spelled *e*; / $\hat{o}$ / spelled *oo*; compound words; initial and final blends; inflection -s; base words and -ed endings; /k/ spelled *ck*

# Rose Got a Note



© Houghton Mifflin Harcourt Publishing Company

Rose can look close. Rose can see lots of bugs in the hole. Rose can take notes, too. Rose can draw a bug.

It is time to go home.

"I had fun," Jake tells Rose.

"I had fun, too," Rose tells Jake.



Rose woke up. Rose put on her robe.  
"This note is for you, Rose," said Mom.  
Mom gave Rose the note.

○ Rose,  
Want to go to the cove  
with me? My mom can  
take us. We can look  
for bugs. Bring a big  
notebook and a pen.  
○ We can write notes  
about what we see.  
It will be lots of fun!  
Your pal,  
○ Jake

This is the nice note Jake wrote to Rose.



Jake and his mom picked up Rose at her home. Then, Rose, Jake, and his mom rode to the cove.

Rose can see bugs under a stone. Jake takes notes. Rose and Jake like the cove.

# Cole Woke Up

## DECODABLE WORDS

Target Skill: Long o (CVCe)

Cole	hope	Poke	Rose
home	joke	rope	woke

## Previously Taught Skills

a	day	is	on	take
and	dog	it	pal	time
at	fast	Jake	pals	trick
best	get	kick	play	tricks
big	has	let	put	up
block	hat	like	run	win
can	his	Mom	spin	yes

SKILLS APPLIED IN WORDS IN STORY: short a; short i; short o; short u; short e; long a (CVCe); long i (CVCe); /k/ spelled c; long o (CVCe); consonants; short vowels; initial and final blends; long a spelled ay; /k/ spelled ck; /z/ spelled s; inflection -s

## HIGH-FREQUENCY WORDS

a	family	said	to	with
be	go	school	today	
do	I	so	try	
does	now	the	will	

# Cole Woke Up



**High-Frequency Words Taught to Date**

a	brothers	eyes	head	maybe	people	sure	wash
about	brown	fall	hear	me	pictures	surprised	watch
above	buy	family	heard	minute	play	take	water
across	by	far	help	more	please	talk	we
after	call	father	her	most	pull	teacher	were
again	car	few	here	mother	pushed	the	what
all	carry	field	high	my	put	their	where
almost	caught	find	hold	myself	read	there	who
along	city	first	house	near	ready	these	why
always	cold	five	how	never	right	they	window
and	come	fly	I	new	said	think	with
animal	could	follow	idea	night	school	those	work
are	country	food	into	no	second	thought	world
around	covers	for	is	noise	see	three	would
away	cried	four	kinds	nothing	seven	to	write
baby	different	friend	know	now	shall	today	years
ball	do	friendship	large	of	she	together	yellow
be	does	full	laugh	off	should	too	you
bear	done	funny	learning	old	show	took	young
beautiful	don't	give	light	once	sing	toward	your
because	door	go	like	one	small	try	
been	down	goes	listen	only	soil	two	cheer
before	draw	good	little	open	some	under	children
began	earth	great	live	or	sometimes	until	hello
begins	eat	green	long	our	soon	use	hundred
bird	eight	ground	look	out	sorry	very	mind
blue	enough	grow	loudly	over	starts	walk	next
both	even	happy	loved	own	stories	want	other
boy	every	have	make	paper	story	warms	this
bring	everyone	he	many	party	studied	was	

**Decoding skills taught to date:** short *a*; short *i*; short *o*; short *u*; short *e*; closed syllables; long *a* (CVCe); long *i* (CVCe); /k/ spelled *c*; /s/ spelled *c*; long *o* (CVCe); consonants; short vowels; initial and final blends; long *a* spelled *ay*; /k/ spelled *ck*; /z/ spelled *s*; inflection *-s*

# Cole Woke Up



Cole can play with his pals Rose and Jake. Cole can spin his rope and do tricks. Rose and Jake like the tricks Cole does with the rope. Will Cole let his pals take his rope to try to do a trick?



Mom said, "Get up, Cole!"  
 Cole woke up. Mom said, "Today will be the best day."  
 Cole said, "I hope so, Mom."  
 "It is a school day," said Mom.  
 "Yes!" said Cole.



Cole can play with his pals at school.  
Cole can kick, block, kick. Cole can run  
fast. Cole can win! Yes, Cole!  
Now, it is time to go home.



Cole can play at home. His family  
has a dog, Poke, at home. Cole can joke  
with Poke. Cole can put a big hat on  
Poke. Poke is his best pal.



# Big Ice Cubes

## DECODABLE WORDS

Target Skill: long u /yoō/ (CVCe)

cubes      mules      used

### Previously Taught Skills

an	freezers	in	packed	that
at	froze	it	past	them
big	get	lake	path	this
box	got	lakes	piles	time
but	had	long	poles	tired
came	home	made	sawdust	way
carts	homes	make	sell	when
cut	hot	man	stacked	wide
days	ice	men	stay	with
did	icemen	not	take	

SKILLS APPLIED IN WORDS IN STORY: short a; short i; CVC syllable pattern; short o; short u; short e; long a (CVCe); long i (CVCe); /k/ spelled c; /s/ spelled c; long o (CVCe), long u /yoō/; consonants; short vowels; base words and ending -ed /d/; long a spelled ai and ay; long e (e, ee), consonants -ck; final blends st; r-controlled vowel ar; digraph th; digraph wh; vowel combinations aw, au

## HIGH-FREQUENCY WORDS

a	cold	house	people	to
and	for	of	the	was
away	have	out	they	were

# Big Ice Cubes



**High-Frequency Words Taught to Date**

a	brothers	eyes	head	maybe	people	sure	wash
about	brown	fall	hear	me	pictures	surprised	watch
above	buy	family	heard	minute	play	take	water
across	by	far	help	more	please	talk	we
after	call	father	her	most	pull	teacher	were
again	car	few	here	mother	pushed	the	what
all	carry	field	high	my	put	their	where
almost	caught	find	hold	myself	read	there	who
along	city	first	house	near	ready	these	why
always	cold	five	how	never	right	they	window
and	come	fly	I	new	said	think	with
animal	could	follow	idea	night	school	those	work
are	country	food	into	no	second	thought	world
around	covers	for	is	noise	see	three	would
away	cried	four	kinds	nothing	seven	to	write
baby	different	friend	know	now	shall	today	years
ball	do	friendship	large	of	she	together	yellow
be	does	full	laugh	off	should	too	you
bear	done	funny	learning	old	show	took	young
beautiful	don't	give	light	once	sing	toward	your
because	door	go	like	one	small	try	
been	down	goes	listen	only	soil	two	cheer
before	draw	good	little	open	some	under	children
began	earth	great	live	or	sometimes	until	hello
begins	eat	green	long	our	soon	use	hundred
bird	eight	ground	look	out	sorry	very	mind
blue	enough	grow	loudly	over	starts	walk	next
both	even	happy	loved	own	stories	want	other
boy	every	have	make	paper	story	warms	this
bring	everyone	he	many	party	studied	was	

**Decoding skills taught to date:** short *a*; short *i*; CVC syllable pattern; short *o*; short *u*; short *e*; long *a* (CVCe); long *i* (CVCe); /k/ spelled *c*; /s/ spelled *c*; long *o* (CVCe), long *u* /yōō/; consonants; short vowels; base words and ending *-ed* /d/; long *a* spelled *ai* and *ay*; long *e* (*e*, *ee*); consonants *-ck*; final blends *st*; *r*-controlled vowel *ar*; digraph *th*; digraph *wh*; vowel combinations *aw*, *au*

# Big Ice Cubes



In the past, homes did not have freezers in them. People had to get ice out of lakes that froze. When the lake froze, icemen cut big cubes of ice.



When hot days came, the big ice cubes were cut. Men used mules and carts to take ice away to sell. At home, people kept ice in an ice box!

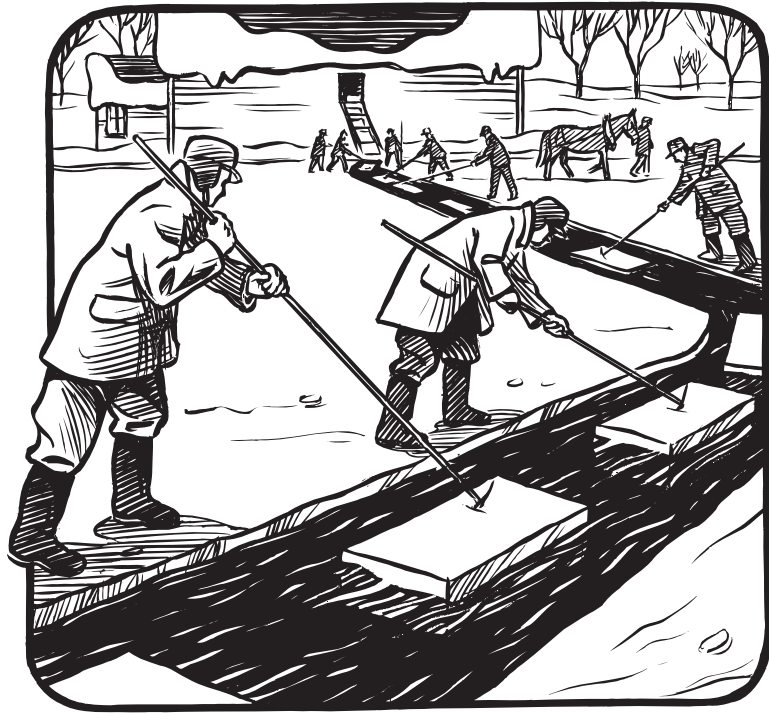

Next, icemen cut ice to make a wide path. They used poles to get big cubes to an ice house. The men got tired with the big ice cubes, but the men got used to it.



An ice house was big. Icemen made big, big piles of stacked ice cubes. Icemen packed the big ice cubes with sawdust. This let kept ice cubes stay cold for a long, long, long, long time.

## Cute Moles

### DECODABLE WORDS

Target Skill: long u /yōō/ (CVCe)

cute huge mule use

### Previously Taught Skills

asked	grass	it	not	sun	yes
but	hole	like	ride	take	
can	home	lost	safe	them	
did	hot	moles	spotted	this	
gave	in	much	stay	us	
get	is	Nat	step	well	

SKILLS APPLIED IN WORDS IN STORY: short a; short i; CVC syllable pattern; short o; short u; short e; long a (CVCe); long i (CVCe); /k/ spelled c; /s/ spelled c; long o (CVCe); consonants; short vowels; double final consonants //; double final consonants ss; blends with r; blends with s; base words and ending -ed /ed/; base words and ending -ed /t/; digraphs ch; long a spelled ai and ay

### HIGH-FREQUENCY WORDS

a	I	said	what
door	our	the	you
ground	please	too	

long u /yōō/ (CVCe)

**BOOK 26**

# Cute Moles



**High-Frequency Words Taught to Date**

a	brothers	eyes	head	maybe	people	sure	wash
about	brown	fall	hear	me	pictures	surprised	watch
above	buy	family	heard	minute	play	take	water
across	by	far	help	more	please	talk	we
after	call	father	her	most	pull	teacher	were
again	car	few	here	mother	pushed	the	what
all	carry	field	high	my	put	their	where
almost	caught	find	hold	myself	read	there	who
along	city	first	house	near	ready	these	why
always	cold	five	how	never	right	they	window
and	come	fly	I	new	said	think	with
animal	could	follow	idea	night	school	those	work
are	country	food	into	no	second	thought	world
around	covers	for	is	noise	see	three	would
away	cried	four	kinds	nothing	seven	to	write
baby	different	friend	know	now	shall	today	years
ball	do	friendship	large	of	she	together	yellow
be	does	full	laugh	off	should	too	you
bear	done	funny	learning	old	show	took	young
beautiful	don't	give	light	once	sing	toward	your
because	door	go	like	one	small	try	
been	down	goes	listen	only	soil	two	cheer
before	draw	good	little	open	some	under	children
began	earth	great	live	or	sometimes	until	hello
begins	eat	green	long	our	soon	use	hundred
bird	eight	ground	look	out	sorry	very	mind
blue	enough	grow	loudly	over	starts	walk	next
both	even	happy	loved	own	stories	want	other
boy	every	have	make	paper	story	warms	this
bring	everyone	he	many	party	studied	was	

**Decoding skills taught to date:** short *a*; short *i*; CVC syllable pattern; short *o*; short *u*; short *e*; long *a* (CVCe); long *i* (CVCe); /k/ spelled *c*; /s/ spelled *c*; long *o* (CVCe), long *u* /yōō/; consonants; short vowels; double final consonants *ll*; double final consonants *ss*; blends with *r*; blends with *s*; base words and ending *-ed* /ed/; base words and ending *-ed* /t/; digraph *ch*; long *a* spelled *ai* and *ay*



# Cute Moles



"I step in this huge hole too much," said Nat Mule. "It is not safe. Please get a door!"



Moles stay in holes in the ground, but Nat Mule spotted cute moles in the hot, hot sun.

"Lost?" asked Nat Mule.

"Yes," said the cute moles. "Can you take us home?"





"What is your mole home like?" asked Nat Mule.

"Cute moles stay in huge holes! Our home is in the grass," said the cute moles.

"A huge hole in the grass? I know it well!" said Nat Mule. Nat Mule gave them a ride home



"Is this it?" asked Nat Mule.

"Yes! How did you know?" asked the cute moles.

# June's Flute

## DECODABLE WORDS

Target Skill: long u /ōō/ (CVCe)

flute	June's	tune
June	Luke	tunes

## Previously Taught Skills

and	clap	is	no	six
at	Dad	it	on	when
be	dog	like	pick	will
best	for	likes	she	with
big	fun	lot	show	
but	has	Mom	sing	
can	in	nice	sings	

SKILLS APPLIED IN WORDS IN STORY: short a; short i; short o; short u; short e; long i (CVCe); /k/ spelled c; /s/ spelled c; long u /ōō/ (CVCe); consonants; short vowels; /z/ spelled s; inflection -s; consonants -ck; blends with l; final blend nt; final blend st; digraph th; possessives with 's; digraph wh; long o (CV); long e (e); final consonants ng; r-controlled or

## HIGH-FREQUENCY WORDS

a	people	the
her	play	to
one	plays	

© Houghton Mifflin Harcourt Publishing Company

long u /ōō/ (CVCe)

**BOOK 27**

# June's Flute



**High-Frequency Words Taught to Date**

a	brothers	eyes	head	maybe	people	sure	wash
about	brown	fall	hear	me	pictures	surprised	watch
above	buy	family	heard	minute	play	take	water
across	by	far	help	more	please	talk	we
after	call	father	her	most	pull	teacher	were
again	car	few	here	mother	pushed	the	what
all	carry	field	high	my	put	their	where
almost	caught	find	hold	myself	read	there	who
along	city	first	house	near	ready	these	why
always	cold	five	how	never	right	they	window
and	come	fly	I	new	said	think	with
animal	could	follow	idea	night	school	those	work
are	country	food	into	no	second	thought	world
around	covers	for	is	noise	see	three	would
away	cried	four	kinds	nothing	seven	to	write
baby	different	friend	know	now	shall	today	years
ball	do	friendship	large	of	she	together	yellow
be	does	full	laugh	off	should	too	you
bear	done	funny	learning	old	show	took	young
beautiful	don't	give	light	once	sing	toward	your
because	door	go	like	one	small	try	
been	down	goes	listen	only	soil	two	cheer
before	draw	good	little	open	some	under	children
began	earth	great	live	or	sometimes	until	hello
begins	eat	green	long	our	soon	use	hundred
bird	eight	ground	look	out	sorry	very	mind
blue	enough	grow	loudly	over	starts	walk	next
both	even	happy	loved	own	stories	want	other
boy	every	have	make	paper	story	warms	this
bring	everyone	he	many	party	studied	was	

**Decoding skills taught to date:** short *a*; short *i*; closed syllables (CVC); short *o*; short *u*; short *e*; long *a* (CVCe); long *i* (CVCe); /k/ spelled *c*; /s/ spelled *c*; long *o* (CVCe), long *u* /yoʊ/; long *u* /oo/ (CVCe)

# June's Flute



June is six. June has a dog, Luke. June has a flute. June likes to play tunes on her flute for Luke.



June plays "June's Tune" and "The Big Tune" for Mom and Dad. They like "June's Tune" best. June plays it at the flute show. People clap and clap for June's tune. But no one can sing like Luke can.



June plays the flute a lot. She likes to play "June's Tune." It is a fun tune! June likes to play "The Big Tune." Luke sings with June when she plays tunes.



June can be in a flute show. June will pick a nice tune to play on her flute. Will June play "June's Tune"? Will June play "The Big Tune"? Luke likes June's tunes.

# It Is June

## DECODABLE WORDS

Target Skill: long u /ōō/ (CVCe)

Bruce	June	prune	tunes
cute	Luke	spruce	
Duke	Luke's	tube	

## Previously Taught Skills

as	help	it	pup	we
can	helped	me	sing	will
first	his	Mom	this	
game	is	picked	up	

SKILLS APPLIED IN WORDS IN STORY: short a; short i; short o; short u; short e; long a (CVCe); /k/ spelled c; /s/ spelled c; long u /ōō/ (CVCe); consonants; short vowels; /z/ spelled s; final consonants ll; final blend st; digraph th; ending -ed /d/; long e (e); final consonants ng; r-controlled ir

## HIGH-FREQUENCY WORDS

a	every	I	too
blue	few	said	you
called	house	the	

© Houghton Mifflin Harcourt Publishing Company

long u /ōō/ (CVCe)

BOOK 28

# It Is June





**High-Frequency Words Taught to Date**

a	brothers	eyes	head	maybe	people	sure	wash
about	brown	fall	hear	me	pictures	surprised	watch
above	buy	family	heard	minute	play	take	water
across	by	far	help	more	please	talk	we
after	call	father	her	most	pull	teacher	were
again	car	few	here	mother	pushed	the	what
all	carry	field	high	my	put	their	where
almost	caught	find	hold	myself	read	there	who
along	city	first	house	near	ready	these	why
always	cold	five	how	never	right	they	window
and	come	fly	I	new	said	think	with
animal	could	follow	idea	night	school	those	work
are	country	food	into	no	second	thought	world
around	covers	for	is	noise	see	three	would
away	cried	four	kinds	nothing	seven	to	write
baby	different	friend	know	now	shall	today	years
ball	do	friendship	large	of	she	together	yellow
be	does	full	laugh	off	should	too	you
bear	done	funny	learning	old	show	took	young
beautiful	don't	give	light	once	sing	toward	your
because	door	go	like	one	small	try	
been	down	goes	listen	only	soil	two	cheer
before	draw	good	little	open	some	under	children
began	earth	great	live	or	sometimes	until	hello
begins	eat	green	long	our	soon	use	hundred
bird	eight	ground	look	out	sorry	very	mind
blue	enough	grow	loudly	over	starts	walk	next
both	even	happy	loved	own	stories	want	other
boy	every	have	make	paper	story	warms	this
bring	everyone	he	many	party	studied	was	

**Decoding skills taught to date:** short *a*; short *i*; closed syllables (CVC); short *o*; short *u*; short *e*; long *a* (CVCe); long *i* (CVCe); /k/ spelled *c*; /s/ spelled *c*; long *o* (CVCe); long *u* /yoo/ (CVCe); long *u* /oo/ (CVCe)



# It Is June



© Houghton Mifflin Harcourt Publishing Company

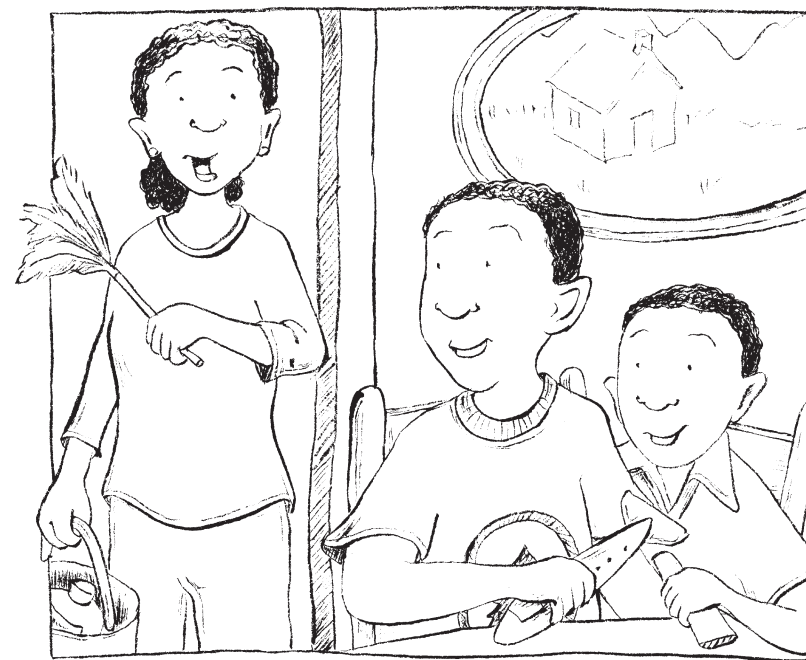

“We can spruce up every June!”  
said Mom.

“Bruce! Luke!” called Mom.  
“It is June first! Will you help me  
spruce up the house?”



"I will prune this blue spruce,"  
said Bruce.

"As I prune, I will sing a few tunes!"



Luke picked up his tube game. Luke's  
cute pup, Duke, helped, too!

## Steve and Eve

### DECODABLE WORDS

Target Skill: long e (CVCe)

Crete	Mede	these
Eve	Steve	

### Previously Taught Skills

and	days	help	let's	then
ask	far	his	map	this
asks	fine	in	Miss	us
at	for	five	on	want
came	from	is	place	write
can	had	it	spoke	wrote
Dad	he	job	that	yes

SKILLS APPLIED IN WORDS IN STORY: short *a*; short *i*; short *o*; short *u*; short *e*; long *a* (CVCe); long *i* (CVCe); /k/ spelled *c*; long *o* (CVCe); /s/ spelled *c*; long *e* (CVCe); consonants; short vowels; /z/ spelled *s*; final consonants *ss*; blends with *r*; blends with *l*; blends with *s*; final blend *nd*; digraph *th*; ending *-s*; digraph *wh*; digraph *wr*; contraction 's; long *e* (e); *r*-controlled *ar*, *or*, *er*

### HIGH-FREQUENCY WORDS

a	here	papers	their	where
about	I	said	to	you
days	look	school	what	

# Steve and Eve



**High-Frequency Words Taught to Date**

a	brothers	eyes	head	maybe	people	sure	wash
about	brown	fall	hear	me	pictures	surprised	watch
above	buy	family	heard	minute	play	take	water
across	by	far	help	more	please	talk	we
after	call	father	her	most	pull	teacher	were
again	car	few	here	mother	pushed	the	what
all	carry	field	high	my	put	their	where
almost	caught	find	hold	myself	read	there	who
along	city	first	house	near	ready	these	why
always	cold	five	how	never	right	they	window
and	come	fly	I	new	said	think	with
animal	could	follow	idea	night	school	those	work
are	country	food	into	no	second	thought	world
around	covers	for	is	noise	see	three	would
away	cried	four	kinds	nothing	seven	to	write
baby	different	friend	know	now	shall	today	years
ball	do	friendship	large	of	she	together	yellow
be	does	full	laugh	off	should	too	you
bear	done	funny	learning	old	show	took	young
beautiful	don't	give	light	once	sing	toward	your
because	door	go	like	one	small	try	
been	down	goes	listen	only	soil	two	cheer
before	draw	good	little	open	some	under	children
began	earth	great	live	or	sometimes	until	hello
begins	eat	green	long	our	soon	use	hundred
bird	eight	ground	look	out	sorry	very	mind
blue	enough	grow	loudly	over	starts	walk	next
both	even	happy	loved	own	stories	want	other
boy	every	have	make	paper	story	warms	this
bring	everyone	he	many	party	studied	was	

**Decoding skills taught to date:** short *a*; short *i*; closed syllables (CVC); short *o*; short *u*; short *e*; long *a* (CVCe); long *i* (CVCe); /k/ spelled *c*; /s/ spelled *c*; long *o* (CVCe); long *u* /yōō/ (CVCe); long *u* /ōō/ (CVCe); long *e* (CVCe)



© Houghton Mifflin Harcourt Publishing Company

Dad spoke about Crete. Then Eve and Steve wrote their papers on Crete.

Steve and Eve had Dad look at their papers. "This is a fine job," said Dad.

# Steve and Eve



Steve and Eve had to write for school. Miss Mede said, "Write about a place that is far from here. I want these papers in five days."



© Houghton Mifflin Harcourt Publishing Company

"Eve, what can you write?" asks Steve.  
"Let's ask Dad. He can help us," said Eve.  
"Yes, Dad came from Crete. Crete is a fine place to write about," said Steve.



"Where is Crete?" Steve asks Dad.  
"Yes, where is Crete?" Eve asks Dad.  
Dad had a map. "Here is Crete. Crete is far."



## Pete, Eve, and Zeke

### DECODABLE WORDS

Target Skill: long e (CVCe)

Eve            Pete            Zeke

### Previously Taught Skills

and	fast	hike	not	take
back	fit	hill	on	tall
bus	flag	hilltop	run	then
but	get	hole	runs	tug
calls	glad	in	see	up
can	grass	is	sit	wags
dog	he	it	stuck	will

SKILLS APPLIED IN WORDS IN STORY: short a; short i; closed syllables (CVC); short o; short u; short e; long a (CVCe); long i (CVCe); /k/ spelled c; long o (CVCe); long e (CVCe); consonants; short vowels; /z/ spelled s; final consonants ll; final consonants ss; consonants -ck; blends with r; blends with l; blends with s; final blend nd; final blend st; digraph th; ending -s; compound words; long e (e)

### HIGH-FREQUENCY WORDS

a	hear	see	they
down	I	the	to
far	said	their	

# Pete, Eve, and Zeke





**High-Frequency Words Taught to Date**

a	brothers	eyes	head	maybe	people	sure	wash
about	brown	fall	hear	me	pictures	surprised	watch
above	buy	family	heard	minute	play	take	water
across	by	far	help	more	please	talk	we
after	call	father	her	most	pull	teacher	were
again	car	few	here	mother	pushed	the	what
all	carry	field	high	my	put	their	where
almost	caught	find	hold	myself	read	there	who
along	city	first	house	near	ready	these	why
always	cold	five	how	never	right	they	window
and	come	fly	I	new	said	think	with
animal	could	follow	idea	night	school	those	work
are	country	food	into	no	second	thought	world
around	covers	for	is	noise	see	three	would
away	cried	four	kinds	nothing	seven	to	write
baby	different	friend	know	now	shall	today	years
ball	do	friendship	large	of	she	together	yellow
be	does	full	laugh	off	should	too	you
bear	done	funny	learning	old	show	took	young
beautiful	don't	give	light	once	sing	toward	your
because	door	go	like	one	small	try	
been	down	goes	listen	only	soil	two	cheer
before	draw	good	little	open	some	under	children
began	earth	great	live	or	sometimes	until	hello
begins	eat	green	long	our	soon	use	hundred
bird	eight	ground	look	out	sorry	very	mind
blue	enough	grow	loudly	over	starts	walk	next
both	even	happy	loved	own	stories	want	other
boy	every	have	make	paper	story	warms	this
bring	everyone	he	many	party	studied	was	

**Decoding skills taught to date:** short *a*; short *i*; closed syllables (CVC); short *o*; short *u*; short *e*; long *a* (CVCe); long *i* (CVCe); /k/ spelled *c*; /s/ spelled *c*; long *o* (CVCe); long *u* /yōō/ (CVCe); long *u* /ōō/ (CVCe); long *e* (CVCe)



Eve said, "I can see a hole in the hill.  
Will it fit Zeke?"

It will fit Zeke! Zeke is stuck! Eve and  
Pete tug, tug, tug Zeke. Zeke is glad. He  
wags, wags, wags.

Then Zeke, Eve, and Pete run fast,  
fast, fast back down the hill.

# Pete, Eve, and Zeke



Pete and Eve hike up the hill. They  
take their dog, Zeke. Zeke runs up the  
hill fast, fast, fast. Then he runs back to  
Pete and Eve.

The hill is tall. Pete and Eve can not  
run fast. Then Pete, Eve, and Zeke get to  
the hilltop.

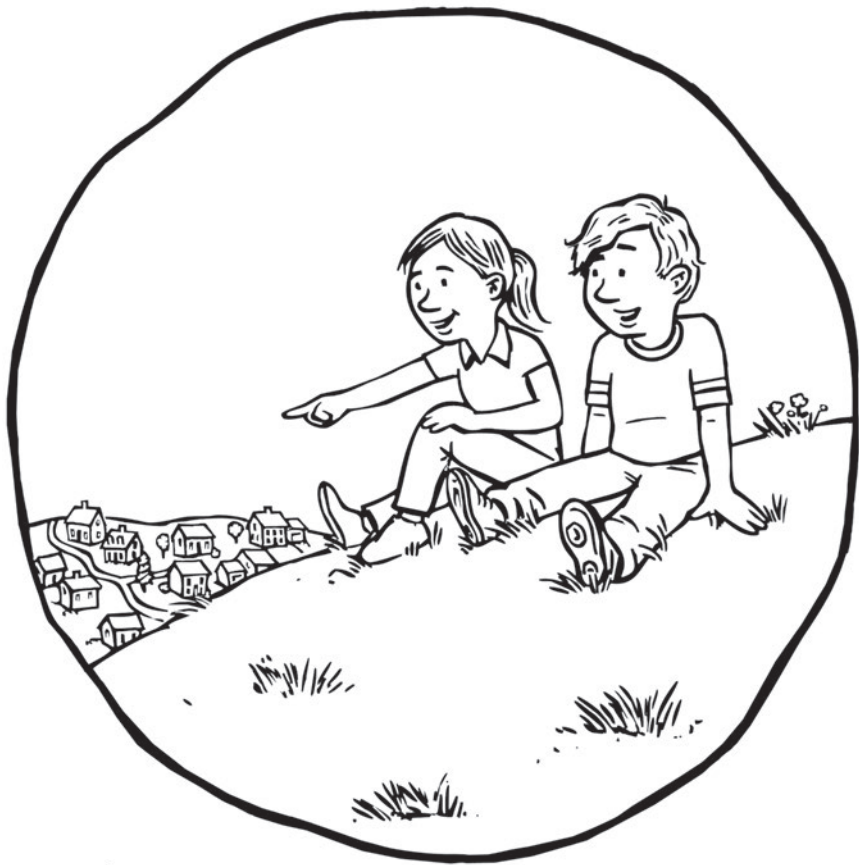

Pete and Eve sit on the grass. They can see far.

"I can see a bus," said Pete.

"I can see a flag," said Eve.



Then Pete said, "I can hear Zeke, but I can not see Zeke."

Pete calls, "Zeke! Zeke! Zeke!"

Eve calls, "Zeke! Zeke! Zeke!"

# Big, Big Rig

## DECODABLE WORDS

Target Skill: /g/ spelled g

big      get      go      Meg      rig

## Previously Taught Skills

and	fine	in	ride	take
belts	hats	is	rides	up
can	helps	next	safe	will
Dad	his	on	sit	

SKILLS APPLIED IN WORDS IN STORY: short a; short i; short o; short u; short e; long a (CVCe); long i (CVCe); /k/ spelled c; /g/ spelled g; consonants; short vowels; /z/ spelled s; inflection -s; final consonants //; final blend nd; ending -s; long o (CV)

## HIGH-FREQUENCY WORDS

a	look	they	where
are	the	to	with

© Houghton Mifflin Harcourt Publishing Company

/g/ spelled g

**BOOK 31**

# Big, Big Rig

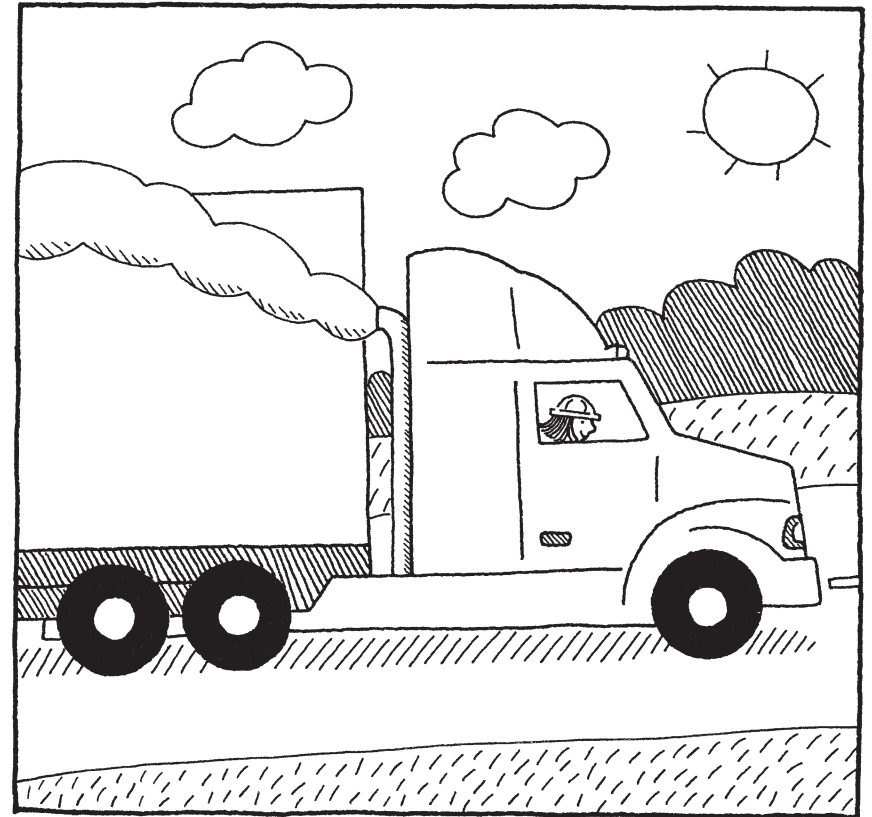

Houghton Mifflin Harcourt.  
The Learning Company™

**High-Frequency Words Taught to Date**

a	brothers	eyes	head	maybe	people	sure	wash
about	brown	fall	hear	me	pictures	surprised	watch
above	buy	family	heard	minute	play	take	water
across	by	far	help	more	please	talk	we
after	call	father	her	most	pull	teacher	were
again	car	few	here	mother	pushed	the	what
all	carry	field	high	my	put	their	where
almost	caught	find	hold	myself	read	there	who
along	city	first	house	near	ready	these	why
always	cold	five	how	never	right	they	window
and	come	fly	I	new	said	think	with
animal	could	follow	idea	night	school	those	work
are	country	food	into	no	second	thought	world
around	covers	for	is	noise	see	three	would
away	cried	four	kinds	nothing	seven	to	write
baby	different	friend	know	now	shall	today	years
ball	do	friendship	large	of	she	together	yellow
be	does	full	laugh	off	should	too	you
bear	done	funny	learning	old	show	took	young
beautiful	don't	give	light	once	sing	toward	your
because	door	go	like	one	small	try	
been	down	goes	listen	only	soil	two	cheer
before	draw	good	little	open	some	under	children
began	earth	great	live	or	sometimes	until	hello
begins	eat	green	long	our	soon	use	hundred
bird	eight	ground	look	out	sorry	very	mind
blue	enough	grow	loudly	over	starts	walk	next
both	even	happy	loved	own	stories	want	other
boy	every	have	make	paper	story	warms	this
bring	everyone	he	many	party	studied	was	

**Decoding skills taught to date:** short *a*; short *i*; closed syllables (CVC); short *o*; short *u*; short *e*; long *a* (CVCe); long *i* (CVCe); /k/ spelled *c*; /s/ spelled *c*; long *o* (CVCe); long *u* /yōō/ (CVCe); long *u* /ōō/ (CVCe); long *e* (CVCe); /g/ spelled *g*

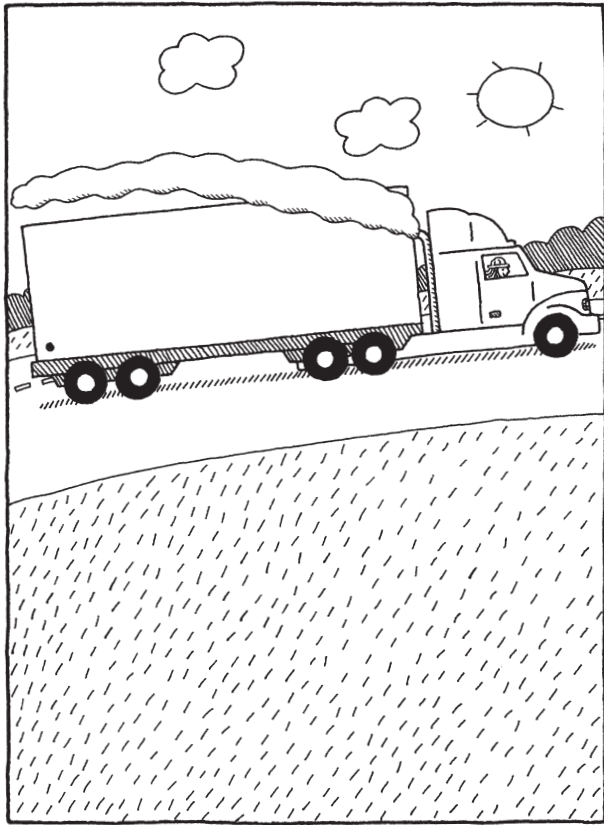

Go, big, big rig! Where will the big rig go? The big rig will take Meg and Dad on a fine ride. Go, big, big rig! Go!

# Big, Big Rig



Look at Meg and Dad. Meg helps Dad on his rig. Dad rides a big, big rig. Meg rides next to Dad.

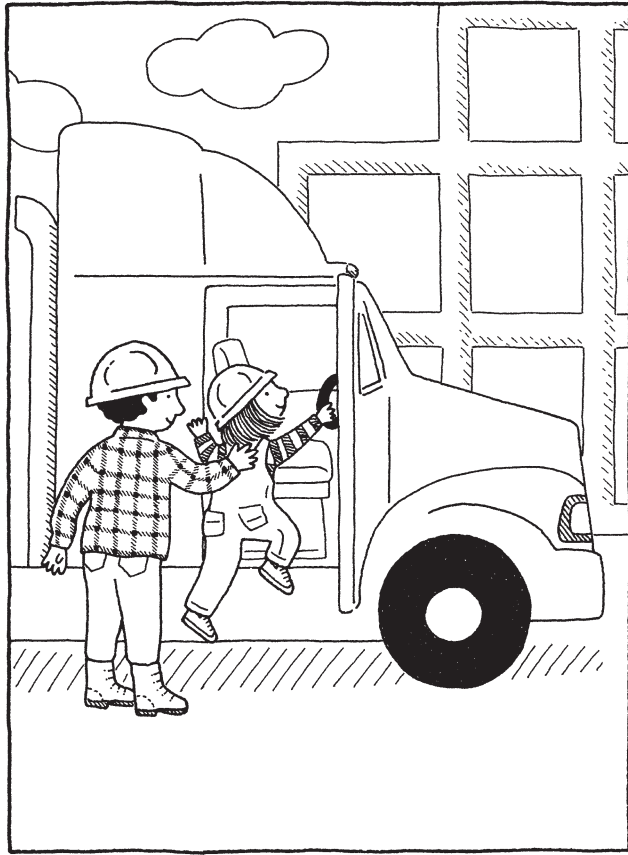

Meg and Dad can go in the big, big rig. Dad helps Meg get up. Meg is safe with Dad.



Meg and Dad sit in the big, big rig. They are safe with belts and hats. Where will Meg and Dad go in the big, big rig?



# Here, Rex!

## DECODABLE WORDS

Target Skill: /g/ spelled g

bag	dog	get	Meg's
beg	Gabe	Meg	

## Previously Taught Skills

and	bite	it	not	smile
at	bites	like	Rex	stop
back	can	mad	runs	will
bib	has	must	sat	
bit	is	named	save	

SKILLS APPLIED IN WORDS IN STORY: short a; short i; short o; short u; short e; long a (CVCe); long i (CVCe); /k/ spelled c; /g/ spelled g; consonants; short vowels; /z/ spelled s; inflection -s; final consonants //; consonants -ck; blends with s; final blend st; ending -s; ending -ed /d/; possessives with 's

## HIGH-FREQUENCY WORDS

a	happy	they
are	here	to
do	now	what

© Houghton Mifflin Harcourt Publishing Company

/g/ spelled g

**BOOK 32**

# Here, Rex!

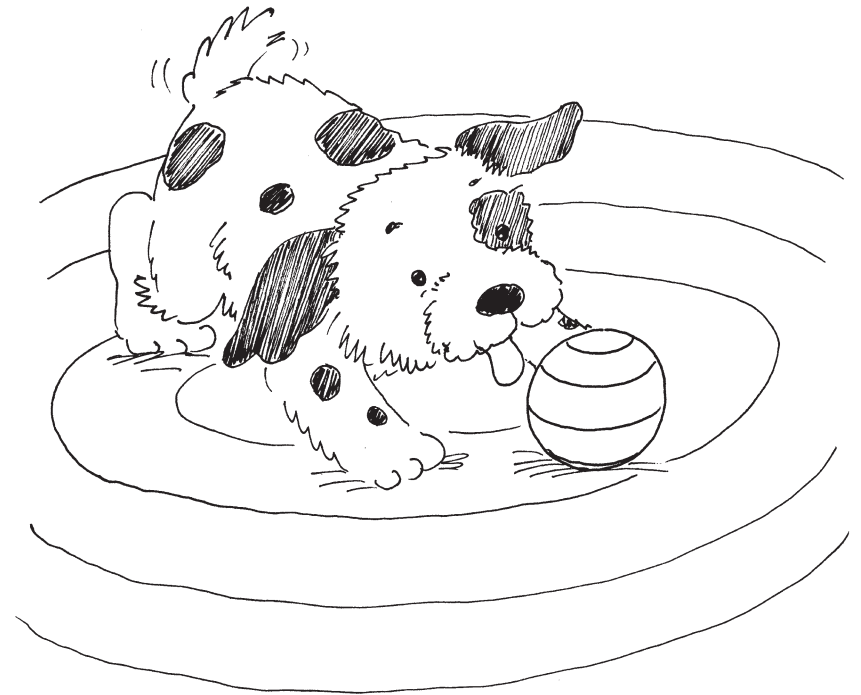

**High-Frequency Words Taught to Date**

a	brothers	eyes	head	maybe	people	sure	wash
about	brown	fall	hear	me	pictures	surprised	watch
above	buy	family	heard	minute	play	take	water
across	by	far	help	more	please	talk	we
after	call	father	her	most	pull	teacher	were
again	car	few	here	mother	pushed	the	what
all	carry	field	high	my	put	their	where
almost	caught	find	hold	myself	read	there	who
along	city	first	house	near	ready	these	why
always	cold	five	how	never	right	they	window
and	come	fly	I	new	said	think	with
animal	could	follow	idea	night	school	those	work
are	country	food	into	no	second	thought	world
around	covers	for	is	noise	see	three	would
away	cried	four	kinds	nothing	seven	to	write
baby	different	friend	know	now	shall	today	years
ball	do	friendship	large	of	she	together	yellow
be	does	full	laugh	off	should	too	you
bear	done	funny	learning	old	show	took	young
beautiful	don't	give	light	once	sing	toward	your
because	door	go	like	one	small	try	
been	down	goes	listen	only	soil	two	cheer
before	draw	good	little	open	some	under	children
began	earth	great	live	or	sometimes	until	hello
begins	eat	green	long	our	soon	use	hundred
bird	eight	ground	look	out	sorry	very	mind
blue	enough	grow	loudly	over	starts	walk	next
both	even	happy	loved	own	stories	want	other
boy	every	have	make	paper	story	warms	this
bring	everyone	he	many	party	studied	was	

**Decoding skills taught to date:** short *a*; short *i*; short *o*; closed syllables (CVC); short *u*; short *e*; long *a* (CVC $\hat{e}$ ); long *i* (CVC $\hat{e}$ ); /k/ spelled *c*; /s/ spelled *c*; long *o* (CVC $\hat{e}$ ); long *u* /y $\hat{o}$ / (CVC $\hat{e}$ ); long *u* / $\hat{o}$ / (CVC $\hat{e}$ ); long *e* (CVC $\hat{e}$ ); /g/ spelled *g*

# Here, Rex!



Rex sat. Gabe and Meg are happy.  
Gabe and Meg smile. Gabe and Meg  
are not mad. They like Rex!



Gabe has a dog named Rex. Rex bites  
a bag and runs! Gabe must get it back!



What can Rex bite now? Rex bites Meg's bib. Meg is mad at Rex! Gabe has to stop Rex. What can Gabe do?



Gabe can beg Rex to stop. Gabe will save Meg's bib!

## Sage Visits College

### DECODABLE WORDS

Target Skill: /j/ spelled *g, dge*

gym	Midge	nudges	Sage
huge	Midge's	pages	wedge

### Previously Taught Skills

and	get	likes	smiles	visit
at	has	lots	take	visits
back	helped	Mom	that	will
bag	helps	must	then	
big	in	pack	this	
but	is	place	time	
Dad	it	ride	us	
fun	last	sis	van	

SKILLS APPLIED IN WORDS IN STORY: short *a*; short *i*; closed syllables (CVC: short *a, i*); short *o*; short *u*; short *e*; closed syllables (CVC: short *o, u, e*); long *a* (CVCe); long *i* (CVCe); /k/ spelled *c*; /s/ spelled *c*; long *o* (CVCe); long *u* /yōō/ (CVCe); long *e* (CVCe); /g/ spelled *g*; /j/ spelled *g, dge*; consonants; short vowels; final consonants *ll*; consonants *ck*; blends with *s*; final blend *nd*; digraph *th*; ending *-s*; ending *ed /t/*; possessives with *'s*

### HIGH-FREQUENCY WORDS

a	her	of	see	the
book	here	said	she	they
have	long	school	soon	to

# Sage and Midge



**High-Frequency Words Taught to Date**

a	brothers	eyes	head	maybe	people	sure	wash
about	brown	fall	hear	me	pictures	surprised	watch
above	buy	family	heard	minute	play	take	water
across	by	far	help	more	please	talk	we
after	call	father	her	most	pull	teacher	were
again	car	few	here	mother	pushed	the	what
all	carry	field	high	my	put	their	where
almost	caught	find	hold	myself	read	there	who
along	city	first	house	near	ready	these	why
always	cold	five	how	never	right	they	window
and	come	fly	I	new	said	think	with
animal	could	follow	idea	night	school	those	work
are	country	food	into	no	second	thought	world
around	covers	for	is	noise	see	three	would
away	cried	four	kinds	nothing	seven	to	write
baby	different	friend	know	now	shall	today	years
ball	do	friendship	large	of	she	together	yellow
be	does	full	laugh	off	should	too	you
bear	done	funny	learning	old	show	took	young
beautiful	don't	give	light	once	sing	toward	your
because	door	go	like	one	small	try	
been	down	goes	listen	only	soil	two	cheer
before	draw	good	little	open	some	under	children
began	earth	great	live	or	sometimes	until	hello
begins	eat	green	long	our	soon	use	hundred
bird	eight	ground	look	out	sorry	very	mind
blue	enough	grow	loudly	over	starts	walk	next
both	even	happy	loved	own	stories	want	other
boy	every	have	make	paper	story	warms	this
bring	everyone	he	many	party	studied	was	

**Decoding skills taught to date:** short *a*; short *i*; closed syllables (CVC: short *a*, *i*); short *o*; short *u*; short *e*; closed syllables (CVC: short *o*, *u*, *e*); long *a* (CVCe); long *i* (CVCe); /k/ spelled *c*; /s/ spelled *c*; long *o* (CVCe); long *u* /*oo*/ (CVCe); long *e* (CVCe); /g/ spelled *g*; /j/ spelled *g*, *dge*



Sage helped Midge get her bag. Then Dad said, "It is time!"

"Have fun, Midge," said Sage. "But visit us soon!"

# Sage and Midge

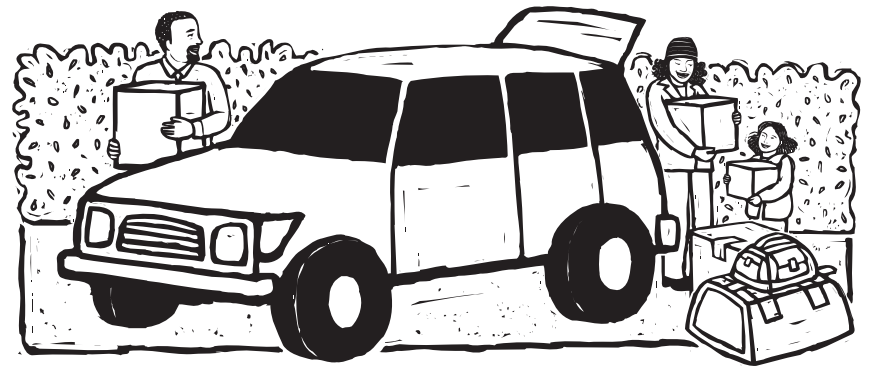

Sage has a big sis, Midge. Midge must get back to her big school. Sage, Mom, and Dad will take Midge.

Midge and Sage pack. Sage helps Midge wedge a huge bag in the van.





It is a long ride. Midge has a big, big book. "That book is huge. It has lots of pages!" said Sage.



At last, they get to Midge's school. They see a big gym.

Sage nudges Midge. "This gym is huge!"

Midge smiles. She likes it here!

## Page and Smudge

### DECODABLE WORDS

Target Skill: /j/ spelled *g, dge*

bridge	edge	nudged	smudged
budge	hedge	Page	wedged
budged	lodge	Smudge	

### Previously Taught Skills

and	came	is	spilled	wet
as	can	Mom	still	went
at	did	mud	stuck	will
back	dog	not	then	with
be	get	on	this	yelled
but	her	ran	try	
by	in	sad	we	

SKILLS APPLIED IN WORDS IN STORY: short *a*; short *i*; closed syllables (CVC: short *a, i*); short *o*; short *u*; short *e*; closed syllables (CVC: short *o, u, e*); long *a* (CVGe); /k/ spelled *c*; consonant *g* (hard *g*); /j/ spelled *g, dge*; consonants; short vowels; final consonants *l*; consonants *ck*; blends with *r*; blends with *s*; final blend *nd*; digraph *th*; ending *-ed*; digraph *sh*; *r*-controlled *er, ir, -or, ur*; long *i* spelled *y*

### HIGH-FREQUENCY WORDS

a	do	out	she	to
are	now	said	soon	was
around	of	saw	the	water

# Page and Smudge



**High-Frequency Words Taught to Date**

a	brothers	eyes	head	maybe	people	sure	wash
about	brown	fall	hear	me	pictures	surprised	watch
above	buy	family	heard	minute	play	take	water
across	by	far	help	more	please	talk	we
after	call	father	her	most	pull	teacher	were
again	car	few	here	mother	pushed	the	what
all	carry	field	high	my	put	their	where
almost	caught	find	hold	myself	read	there	who
along	city	first	house	near	ready	these	why
always	cold	five	how	never	right	they	window
and	come	fly	l	new	said	think	with
animal	could	follow	idea	night	school	those	work
are	country	food	into	no	second	thought	world
around	covers	for	is	noise	see	three	would
away	cried	four	kinds	nothing	seven	to	write
baby	different	friend	know	now	shall	today	years
ball	do	friendship	large	of	she	together	yellow
be	does	full	laugh	off	should	too	you
bear	don't	funny	learning	old	show	took	young
beautiful	done	give	light	once	sing	toward	your
because	door	go	like	one	small	try	
been	down	goes	listen	only	soil	two	cheer
before	draw	good	little	open	some	under	children
began	earth	great	live	or	sometimes	until	hello
begins	eat	green	long	our	soon	use	hundred
bird	eight	ground	look	out	sorry	very	mind
blue	enough	grow	loudly	over	starts	walk	next
both	even	happy	loved	own	stories	want	other
boy	every	have	make	paper	story	warms	this
bring	everyone	he	many	party	studied	was	

**Decoding skills taught to date:** short *a*; short *i*; closed syllables (CVC: short *a*, *î*); short *o*; short *u*; short *e*; closed syllables (CVC: short *o*, *u*, *e*); long *a* (CVCe); long *i* (CVCe); /k/ spelled *c*; /s/ spelled *c*; long *o* (CVCe); long *u* /yōō/ (CVCe); long *u* /ōō/ (CVCe); long *e* (CVCe); consonant *g* (hard *g*); /j/ spelled *g*, *dge*

# Page and Smudge



“Page, try to budge Smudge now,”  
Mom said. Then Smudge budged!

“Now we are smudged with mud!”  
said Mom.

“And Smudge is wet!” said Page.



“Smudge! Smudge!” Page yelled as  
she went on the bridge. Then she saw  
her dog, Smudge, in a hedge. Page ran  
to the hedge. Smudge was wedged in by  
the hedge and the lodge.



Page nudged Smudge, but Smudge did not budge. Smudge was stuck!

Then Page saw Mom at the edge of the bridge. Page yelled, "Mom, Smudge is stuck and will not budge!"

Page and Mom nudged Smudge. Smudge still did not budge!



Mom ran back to the bridge. Then she came back with a can of water.

"We can try this," Mom said. She spilled water around Smudge. Smudge dodged the water, but Smudge still did not budge.

"Do not be sad," said Mom. "We will get Smudge out!"

# Greg Gets a Pet

## DECODABLE WORDS

Target Skill: blends with *r*

branch	brown	Fran's	grass
brand	crate	from	Greg
brick	Fran	grand	grin
Brin	Frank's	grant	tracks

## Previously Taught Skills

and	get	it	played	with
asked	gets	just	shop	yes
big	got	Mom	smiled	up
came	had	name	spot	visit
can	home	next	take	we
dog	I	pet	that	went
fun	is	picked	wish	will

SKILLS APPLIED IN WORDS IN STORY: short *a*; short *i*; closed syllables (CVC: short *a*, *i*); short *o*; short *u*; short *e*; closed syllables (CVC: short *o*, *u*, *e*); long *a* (CVCe); long *i* (CVCe); /*k*/ spelled *c*; long *o* (CVCe); consonant *g* (hard *g*); blends with *r*; consonants; short vowels; words with *oa*, *ow*; inflection *-s*; final consonants *ll*, *ss*; consonants *ck*; final blends *nt*, *nd*, *xt*; digraphs *th*, *ch*, *sh*; ending *-ed*; possessives with *'s*; blends with *s*, *l*; words with *ai*, *ay*

## HIGH-FREQUENCY WORDS

a	my	the
for	new	to
house	said	what

© Houghton Mifflin Harcourt Publishing Company

blends with *r*

BOOK 35

# Greg Gets a Pet





**High-Frequency Words Taught to Date**

a	brown	family	help	most	pushed	their	who
about	buy	far	her	mother	put	there	why
above	by	father	here	my	read	these	window
across	call	few	high	myself	ready	they	with
after	car	field	hold	near	right	think	work
again	carry	find	house	never	said	those	world
all	caught	first	how	new	school	thought	would
almost	city	five	I	night	second	three	write
along	cold	fly	idea	no	see	to	years
always	come	follow	into	noise	seven	today	yellow
and	could	food	is	nothing	shall	together	you
animal	country	for	kinds	now	she	too	young
are	covers	four	know	of	should	took	your
around	cried	friend	large	off	show	toward	
away	different	friendship	laugh	old	sing	try	cheer
baby	do	full	learning	once	small	two	children
ball	does	funny	light	one	soil	under	hello
be	done	give	like	only	some	until	hundred
bear	don't	go	listen	open	sometimes	use	mind
beautiful	door	goes	little	or	soon	very	next
because	down	good	live	our	sorry	walk	other
been	draw	great	long	out	starts	want	says
before	earth	green	look	over	stories	warms	table
began	eat	ground	loudly	own	story	was	this
begins	eight	grow	loved	paper	studied	wash	
bird	enough	happy	make	party	sure	watch	
blue	even	have	many	people	surprised	water	
both	every	he	maybe	pictures	take	we	
boy	everyone	head	me	play	talk	were	
bring	eyes	hear	minute	please	teacher	what	
brothers	fall	heard	more	pull	the	where	

**Decoding skills taught to date:** short *a*; short *i*; closed syllables (CVC: short *a*, *i*); short *o*; short *u*; short *e*; closed syllables (CVC: short *o*, *u*, *e*); long *a* (CVCe); long *i* (CVCe); /k/ spelled *c*; /s/ spelled *c*; long *o* (CVCe); long *u* /yōō/ (CVCe); long *u* /ōō/ (CVCe); long *e* (CVCe); consonant *g* (hard *g*); /j/ spelled *g*, *dge*; blends with *r*





# Greg Gets a Pet



"Can I take Brin to Fran's house?" asked Greg. "Yes," said Mom.

Greg went to visit Fran. Greg picked up a branch from the grass. Fran and Greg played with Brin.

Brin, Fran, and Greg had fun! Brin is just the dog for Greg!

Greg came home and said, "Mom, I had a grand wish. Can we get a brand new pet?"

"Greg, that is a wish I can grant. What pet will we get?" asked Mom.

"A big brown dog!" said Greg.



Mom and Greg went to Frank's Pet Shop. It is a brick shop next to the tracks.



Greg smiled and said, "I spot a grand dog! I will name my dog Brin!"

Mom and Greg got a crate to take Brin home. Greg had a big grin.

## Drips and Drops on Gran

### DECODABLE WORDS

Target Skill: blends with *r*

brim	drop	from	grins	trek
drip	drops	grabs	grips	
drips	frog	Gran	track	

Previously Taught Skills

and	big	hops	it	stops
at	hat	in	on	wet
bag	her	is	see	

SKILLS APPLIED IN WORDS IN STORY: short *a*; short *i*; closed syllables (CVC: short *a*, *i*); short *o*; short *u*; short *e*; closed syllables (CVC: short *o*, *u*, *e*); consonant *g* (hard *g*); blends with *r*, *s*; consonants; short vowels; /*z*/ spelled *s*; inflection -*s*; consonants *ck*; long *e* (*e*, *ee*); *r*-controlled *er*

### HIGH-FREQUENCY WORDS

a	said	the
I	she	to
rain	starts	

© Houghton Mifflin Harcourt Publishing Company

blends with *r*

BOOK 36

# Drips and Drops on Gran



Houghton Mifflin Harcourt.  
The Learning Company™

**High-Frequency Words Taught to Date**

a	brown	family	help	most	pushed	their	who
about	buy	far	her	mother	put	there	why
above	by	father	here	my	read	these	window
across	call	few	high	myself	ready	they	with
after	car	field	hold	near	right	think	work
again	carry	find	house	never	said	those	world
all	caught	first	how	new	school	thought	would
almost	city	five	I	night	second	three	write
along	cold	fly	idea	no	see	to	years
always	come	follow	into	noise	seven	today	yellow
and	could	food	is	nothing	shall	together	you
animal	country	for	kinds	now	she	too	young
are	covers	four	know	of	should	took	your
around	cried	friend	large	off	show	toward	
away	different	friendship	laugh	old	sing	try	cheer
baby	do	full	learning	once	small	two	children
ball	does	funny	light	one	soil	under	hello
be	done	give	like	only	some	until	hundred
bear	don't	go	listen	open	sometimes	use	mind
beautiful	door	goes	little	or	soon	very	next
because	down	good	live	our	sorry	walk	other
been	draw	great	long	out	starts	want	says
before	earth	green	look	over	stories	warms	table
began	eat	ground	loudly	own	story	was	this
begins	eight	grow	loved	paper	studied	wash	
bird	enough	happy	make	party	sure	watch	
blue	even	have	many	people	surprised	water	
both	every	he	maybe	pictures	take	we	
boy	everyone	head	me	play	talk	were	
bring	eyes	hear	minute	please	teacher	what	
brothers	fall	heard	more	pull	the	where	

**Decoding skills taught to date:** short *a*; short *i*; closed syllables (CVC: short *a*, *i*); short *o*; short *u*; short *e*; closed syllables (CVC: short *o*, *u*, *e*); long *a* (CVCe); long *i* (CVCe); /k/ spelled *c*; /s/ spelled *c*; long *o* (CVCe); long *u* /yōō/ (CVCe); long *u* /ōō/ (CVCe); long *e* (CVCe); consonant *g* (hard *g*); /j/ spelled *g*, *dge*; blends with *r*

# Drips and Drops on Gran



Gran is on a trek. She stops on the track.

"I see a frog," said Gran.



The frog hops in the wet drips and drops.

Gran grins at the frog.



It starts to rain. Big wet drops drip on Gran. Drip, drop, drip, drop, drip! Gran grabs a hat from her bag.



Gran grips the brim. Drip, drop, drip, drop, drip! Drops drip from the hat brim.

# Flip's Clay Class

## DECODABLE WORDS

Target Skill: blends with /

black	clay	Flip	glaze	plates
block	clock	Flip's	plan	slid
class	flat	flung	plate	

## Previously Taught Skills

and	dry	is	paint	this
at	fast	last	painted	up
back	gave	made	pressed	we
bag	got	makes	rang	will
bake	had	Miss	rode	with
baked	hard	must	sat	
bed	he	next	she	
bike	his	nice	that	
dressed	in	on	then	

SKILLS APPLIED IN WORDS IN STORY: short *a*; short *i*; short *o*; short *u*; short *e*; closed syllables (CVC: short *a*, *i*, *o*, *u*, *e*); long *a* (CVCe); long *i* (CVCe); /k/ spelled *c*; long *o* (CVCe); consonant *g* (hard *g*); blends with *r*; blends with *l*; consonants; short vowels; long *e* (*e*, *e\_e*); inflection *-s*; final consonants *ll*, *ss*; consonants *ck*; final blends *nd*, *st*, *xt*; digraph *th*; ending *-ed*; possessives with *'s*; digraph *sh*; final consonants *ng*; long *a* (*ai*, *ay*); *r*-controlled *ar*; long *i* spelled *y*

## HIGH-FREQUENCY WORDS

a	our	the	took
everyone	out	to	was
of	said	today	

© Houghton Mifflin Harcourt Publishing Company

blends with /

**BOOK 37**

# Flip's Clay Class



Houghton Mifflin Harcourt.  
The Learning Company™



**High-Frequency Words Taught to Date**

a	brown	family	help	most	pushed	their	who
about	buy	far	her	mother	put	there	why
above	by	father	here	my	read	these	window
across	call	few	high	myself	ready	they	with
after	car	field	hold	near	right	think	work
again	carry	find	house	never	said	those	world
all	caught	first	how	new	school	thought	would
almost	city	five	I	night	second	three	write
along	cold	fly	idea	no	see	to	years
always	come	follow	into	noise	seven	today	yellow
and	could	food	is	nothing	shall	together	you
animal	country	for	kinds	now	she	too	young
are	covers	four	know	of	should	took	your
around	cried	friend	large	off	show	toward	
away	different	friendship	laugh	old	sing	try	cheer
baby	do	full	learning	once	small	two	children
ball	does	funny	light	one	soil	under	hello
be	don't	give	like	only	some	until	hundred
bear	done	go	listen	open	sometimes	use	mind
beautiful	door	goes	little	or	soon	very	next
because	down	good	live	our	sorry	walk	other
been	draw	great	long	out	starts	want	says
before	earth	green	look	over	stories	warms	table
began	eat	ground	loudly	own	story	was	this
begins	eight	grow	loved	paper	studied	wash	
bird	enough	happy	make	party	sure	watch	
blue	even	have	many	people	surprised	water	
both	every	he	maybe	pictures	take	we	
boy	everyone	head	me	play	talk	were	
bring	eyes	hear	minute	please	teacher	what	
brothers	fall	heard	more	pull	the	where	

**Decoding skills taught to date:** short *a*; short *i*; closed syllables (CVC: short *a*, *i*); short *o*; short *u*; short *e*; closed syllables (CVC: short *o*, *u*, *e*); long *a* (CVCe); long *i* (CVCe); /k/ spelled *c*; /s/ spelled *c*; long *o* (CVCe); long *u* /yōō/ (CVCe); long *u* /ōō/ (CVCe); long *e* (CVCe); consonant *g* (hard *g*); /j/ spelled *g*, *dge*; blends with *r*; blends with *l*



At the next class, Flip painted his plate with glaze. Then Miss Black baked the plates.

At last, Flip got his plate back.  
"That is a nice plate, Flip!" said Miss Black.

## Flip's Clay Class



Flip's clock rang. He sat up fast.  
Today was Flip's clay class!

Flip slid out of bed and got dressed.  
Then he got his black bike. He flung his bag on his back. Flip rode to clay class.



© Houghton Mifflin Harcourt Publishing Company



At clay class, Miss Black gave everyone a block of clay.

Flip had a plan. He pressed his clay flat. Flip made a clay plate!

Miss Black took the clay plates. She said, "The clay plates must dry. In our next class we will paint our plates with glaze. Then we will bake the clay plates. This makes the plates hard."

# Quack, Flap, Cluck

## DECODABLE WORDS

**Target Skill:** blends with /

cluck flat  
clucks flock  
flap

### Previously Taught Skills

and ducks not  
bills hen quack  
can in

SKILLS APPLIED IN WORDS IN STORY: short *a*; short *i*; closed syllables (CVC: short *a*, *i*, *o*, *u*, *e*); short *o*; short *u*; short *e*; blends with *l*; consonants; short vowels; consonants *ck*; inflected *-s*; /*z*/ spelled *s*

## HIGH-FREQUENCY WORDS

a have  
do the

© Houghton Mifflin Harcourt Publishing Company

blends with /

**BOOK 38**

# Quack, Flap, Cluck

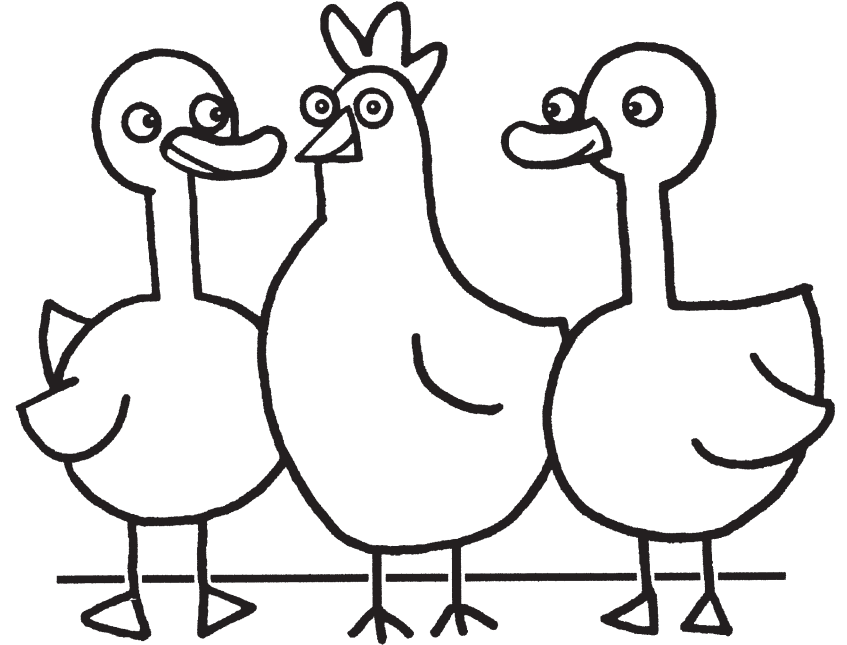

**High-Frequency Words Taught to Date**

a	brown	family	help	most	pushed	their	who
about	buy	far	her	mother	put	there	why
above	by	father	here	my	read	these	window
across	call	few	high	myself	ready	they	with
after	car	field	hold	near	right	think	work
again	carry	find	house	never	said	those	world
all	caught	first	how	new	school	thought	would
almost	city	five	I	night	second	three	write
along	cold	fly	idea	no	see	to	years
always	come	follow	into	noise	seven	today	yellow
and	could	food	is	nothing	shall	together	you
animal	country	for	kinds	now	she	too	young
are	covers	four	know	of	should	took	your
around	cried	friend	large	off	show	toward	
away	different	friendship	laugh	old	sing	try	cheer
baby	do	full	learning	once	small	two	children
ball	does	funny	light	one	soil	under	hello
be	done	give	like	only	some	until	hundred
bear	don't	go	listen	open	sometimes	use	mind
beautiful	door	goes	little	or	soon	very	next
because	down	good	live	our	sorry	walk	other
been	draw	great	long	out	starts	want	says
before	earth	green	look	over	stories	warms	table
began	eat	ground	loudly	own	story	was	this
begins	eight	grow	loved	paper	studied	wash	
bird	enough	happy	make	party	sure	watch	
blue	even	have	many	people	surprised	water	
both	every	he	maybe	pictures	take	we	
boy	everyone	head	me	play	talk	were	
bring	eyes	hear	minute	please	teacher	what	
brothers	fall	heard	more	pull	the	where	

**Decoding skills taught to date:** short *a*; short *i*; closed syllables (CVC: short *a*, *i*); short *o*; short *u*; short *e*; closed syllables (CVC: short *o*, *u*, *e*); long *a* (CVCe); long *i* (CVCe); /k/ spelled *c*; /s/ spelled *c*; long *o* (CVCe); long *u* /yōō/ (CVCe); long *u* /ūū/ (CVCe); long *e* (CVCe); /g/ spelled *g*; /j/ spelled *g*, *dge*; blends with *r*; blends with *l*

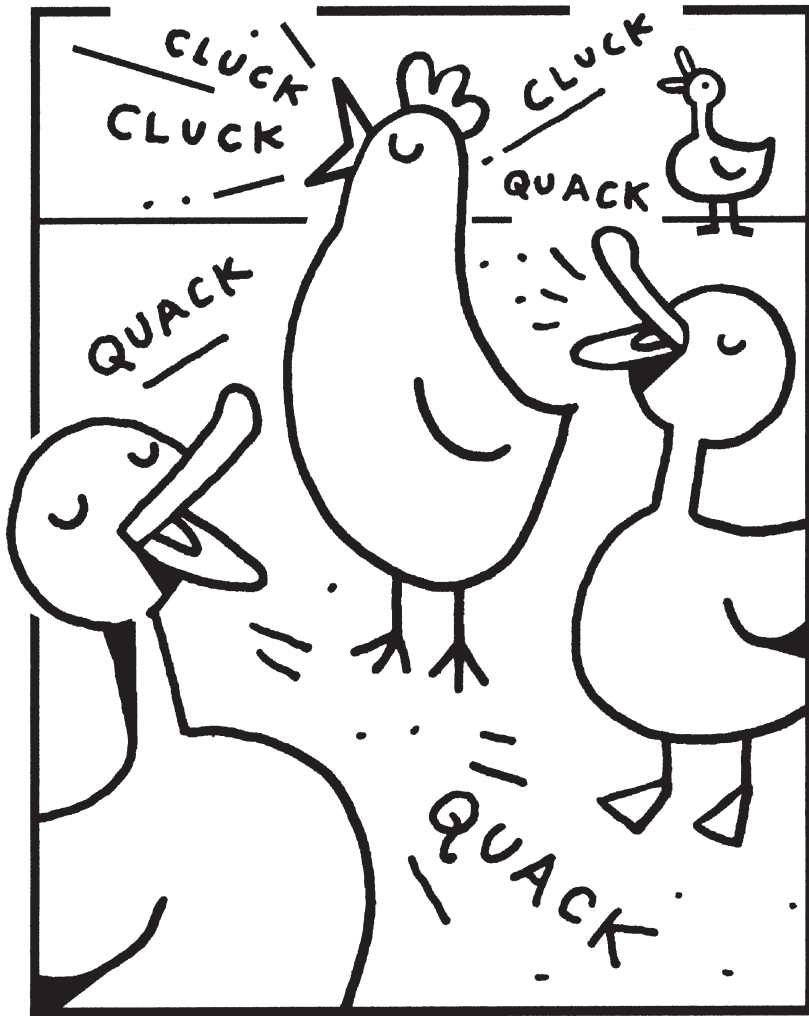

The flock can quack and flap  
and cluck.

Quack, flap, cluck!

© Houghton Mifflin Harcourt Publishing Company

# Quack, Flap, Cluck

blends with /

**BOOK 38**

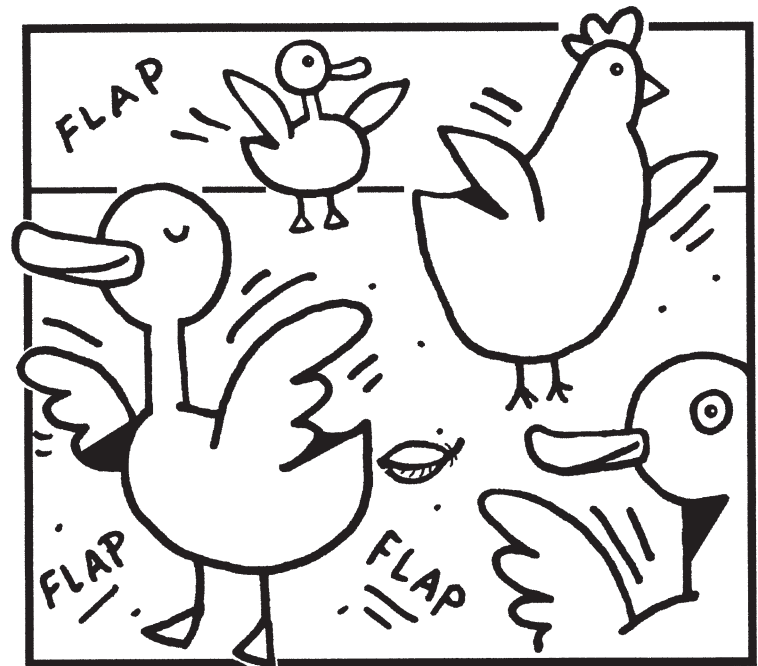

Ducks in the flock flap.

Flap, flap, flap.

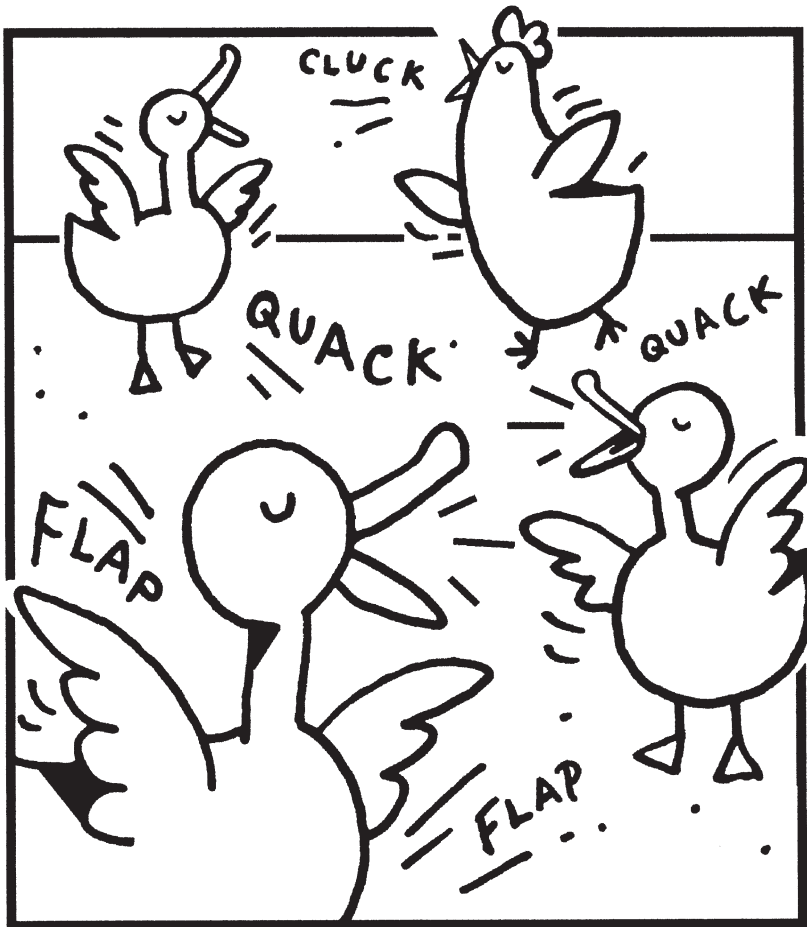

Ducks in the flock have flat bills.  
Ducks in the flock quack.  
Flap, quack. Flap, quack. Cluck.

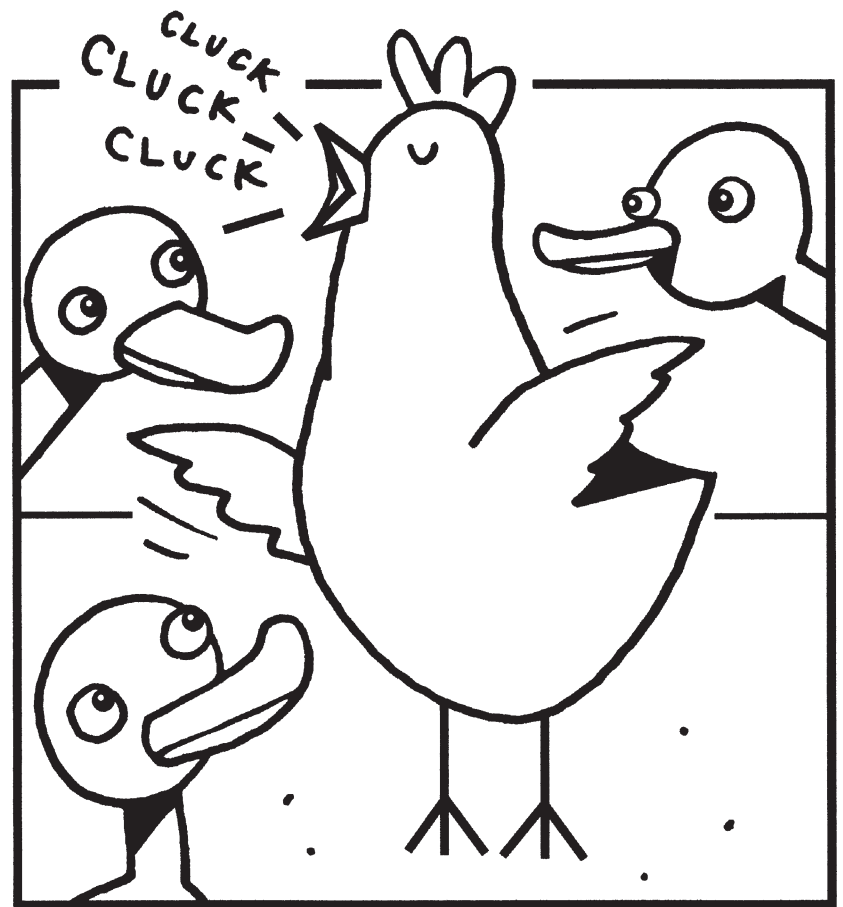

Cluck, cluck, cluck.  
Ducks quack. Ducks do not cluck.  
A hen in the flock clucks!



# Camp Sky

## DECODABLE WORDS

<b>Target Skill:</b>	<b>blends with s</b>			
best	skit	snacks	Stan	Stef
mask	sky	sports	stand	step
scarf	sleep	stage	stars	stops
Skip	small	stamp	start	swim

## Previously Taught Skills

and	gets	like	see	we
camp	he	lots	sees	when
can	his	make	short	
clap	home	note	tells	
dad	is	on	then	
for	it	pals	under	
fun	kids	play	up	

SKILLS APPLIED IN WORDS IN STORY: short *a*; short *i*; short *o*; short *u*; short *e*; CVC closed syllables; long *a* (CVCe); long *i* (CVCe); /k/ spelled *c*; long *o* (CVCe); /g/ spelled *g*; /j/ spelled *g*; blends with *l*; blends with *s*; consonants; short vowels; /z/ spelled *s*; double final consonants: *ll*; consonants *-ck*; final blends: *mp*, *nd*; digraph *th*; base words and ending *-s*; digraph *sh*, *wh*; long *e* (*e*, *ee*); long *a* spelled *y*, *ai* and *ay*; *r*-controlled vowel *ar*; *r*-controlled vowel *or* and *ore*; *r*-controlled vowel *er*, *ir*, and *ur*

## HIGH-FREQUENCY WORDS

a	goes	I	the	what
about	have	of	they	writes
come	help	says	to	you

© Houghton Mifflin Harcourt Publishing Company

blends with s

**BOOK 39**

# Camp Sky

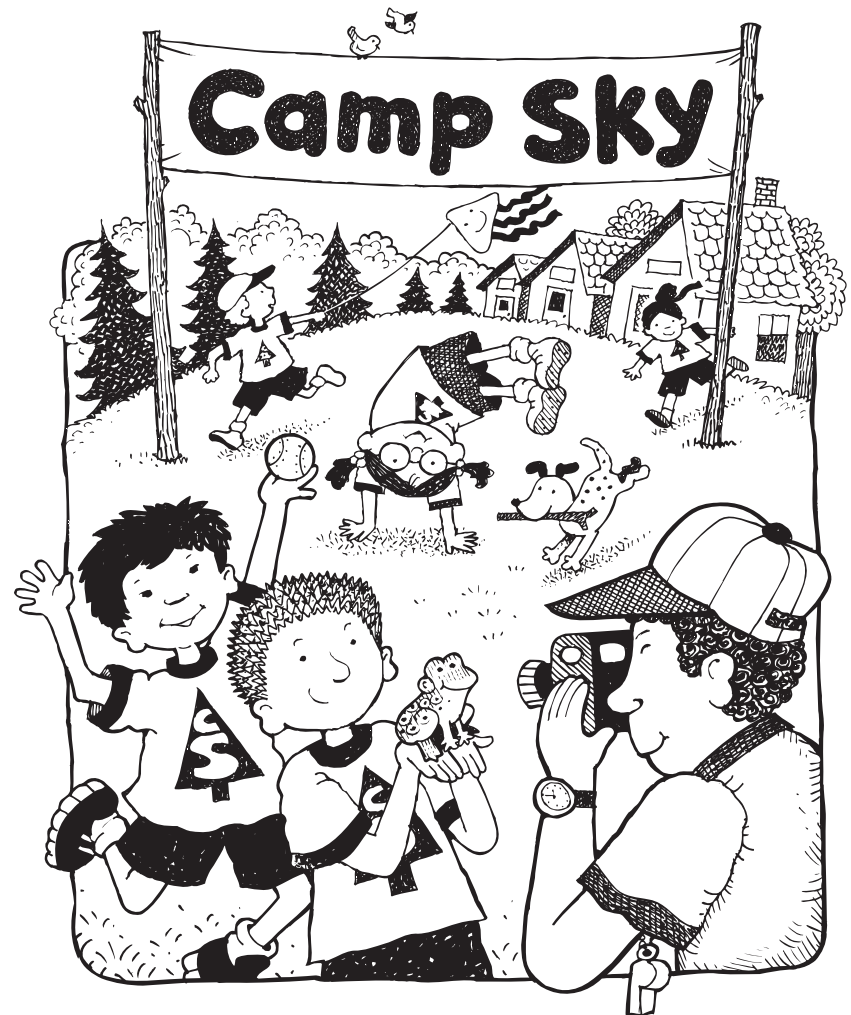

Houghton Mifflin Harcourt.  
The Learning Company™

**High-Frequency Words Taught to Date**

a	brown	family	help	most	pushed	their	who
about	buy	far	her	mother	put	there	why
above	by	father	here	my	read	these	window
across	call	few	high	myself	ready	they	with
after	car	field	hold	near	right	think	work
again	carry	find	house	never	said	those	world
all	caught	first	how	new	school	thought	would
almost	city	five	I	night	second	three	write
along	cold	fly	idea	no	see	to	years
always	come	follow	into	noise	seven	today	yellow
and	could	food	is	nothing	shall	together	you
animal	country	for	kinds	now	she	too	young
are	covers	four	know	of	should	took	your
around	cried	friend	large	off	show	toward	
away	different	friendship	laugh	old	sing	try	cheer
baby	do	full	learning	once	small	two	children
ball	does	funny	light	one	soil	under	hello
be	done	give	like	only	some	until	hundred
bear	don't	go	listen	open	sometimes	use	mind
beautiful	door	goes	little	or	soon	very	next
because	down	good	live	our	sorry	walk	other
been	draw	great	long	out	starts	want	says
before	earth	green	look	over	stories	warms	table
began	eat	ground	loudly	own	story	was	this
begins	eight	grow	loved	paper	studied	wash	
bird	enough	happy	make	party	sure	watch	
blue	even	have	many	people	surprised	water	
both	every	he	maybe	pictures	take	we	
boy	everyone	head	me	play	talk	were	
bring	eyes	hear	minute	please	teacher	what	
brothers	fall	heard	more	pull	the	where	

**Decoding skills taught to date:** short *a*; short *i*; closed syllables (CVC: short *a*, *i*); short *o*; short *u*; short *e*; closed syllables (CVC: short *o*, *u*, *e*); long *a* (CVCe); long *i* (CVCe); /k/ spelled *c*; /s/ spelled *c*; long *o* (CVCe); long *u* /yōō/ (CVCe); long *u* /ōō/ (CVCe); long *e* (CVCe); /g/ spelled *g*; /j/ spelled *g*, *dge*; blends with *r*; blends with *l*; blends with *s*; consonants; short vowels; /z/ spelled *s*; double final consonants: *ll*; consonants *-ck*; final blends *mp*, *nd*; digraph *th*; base words and ending *-s*; digraphs *sh*, *wh*; long *a* (e, ee); long *a* spelled *y*, *ai*, and *ay*; *r*-controlled vowel *ar*; *r*-controlled vowel *or* and *ore*; *r*-controlled vowel *er*, *ir*, and *ur*

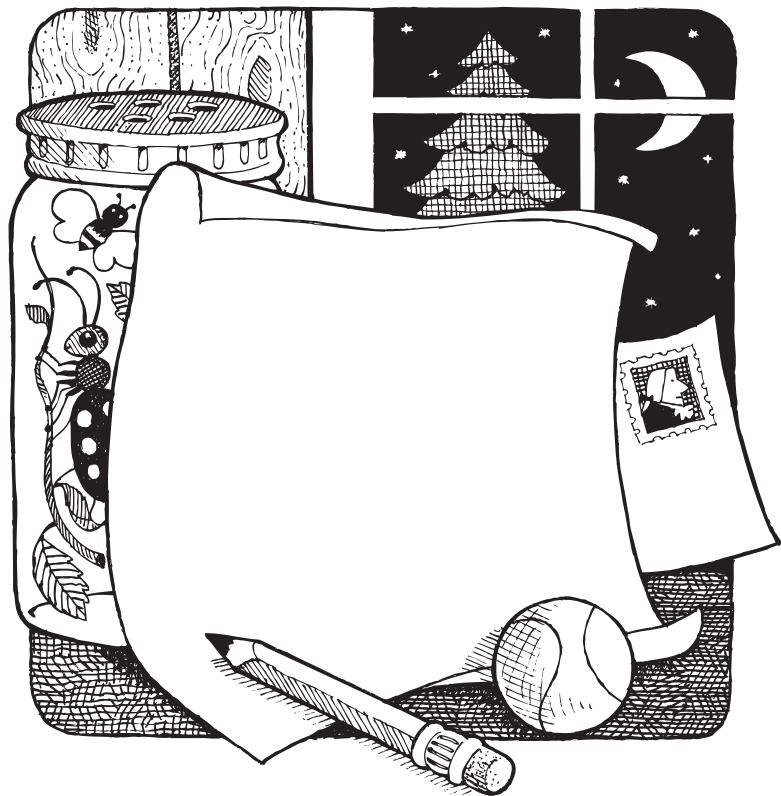

Stan writes a note home. He tells his dad about the skit. Stan gets a stamp for his note. Then Stan goes to sleep.

# Camp Sky



Stan goes to Camp Sky. He says it is the best camp! Stan can swim and play sports. He can have snacks. Stan can sleep under the stars!



© Houghton Mifflin Harcourt Publishing Company



Stan sees his pals, Skip and Stef.  
"Can we make up a skit?" says Skip.  
"A skit is like a short play."  
Stan says, "What fun! Can I help you  
make a stage?"

Lots of kids see the skit. Stan, Skip,  
and Stef have a scarf and a small mask.  
They step on the stage and start. When  
the skit stops, kids stand and clap!

# Stan's Sled

## DECODABLE WORDS

<b>Target Skill:</b>	<b>blends with s</b>			
sled	slides	speeds	Stan's	stuck
slick	smiles	spot	steep	
slide	snow	Stan	still	

## Previously Taught Skills

and	has	his	on
can	he	is	sees
flat	hill	not	will

SKILLS APPLIED IN WORDS IN STORY: short *a*; short *i*; closed syllables (CVC: short *a*, *i*); short *o*; short *u*; short *e*; closed syllables (CVC: short *o*, *u*, *e*); long *i* (CVCe); blends with *i*; blends with *s*; consonants; short vowels; /z/ spelled *s*; inflection -*s*; final consonants *ll*; possessives with *'s*; consonants *ck*; long *e* (*e*, *ee*); long *o* (*oa*, *ow*); final blend *nd*

## HIGH-FREQUENCY WORDS

a  
now  
the

© Houghton Mifflin Harcourt Publishing Company

blends with s

**BOOK 40**

# Stan's Sled

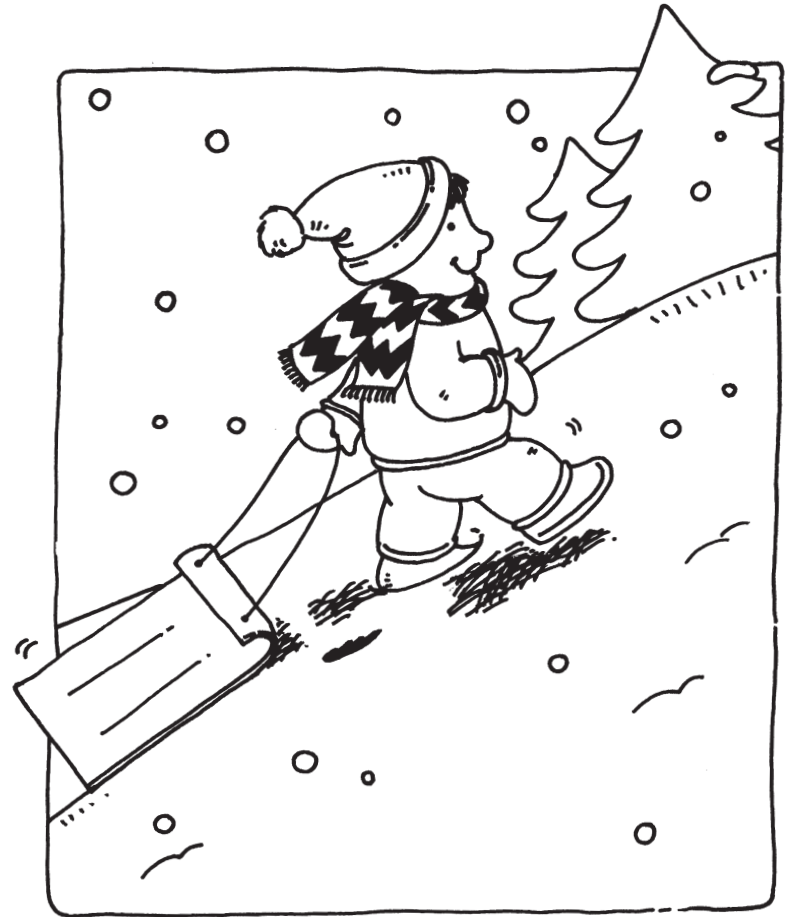

Houghton Mifflin Harcourt.  
The Learning Company™

**High-Frequency Words Taught to Date**

a	brown	family	help	most	pushed	their	who
about	buy	far	her	mother	put	there	why
above	by	father	here	my	read	these	window
across	call	few	high	myself	ready	they	with
after	car	field	hold	near	right	think	work
again	carry	find	house	never	said	those	world
all	caught	first	how	new	school	thought	would
almost	city	five	I	night	second	three	write
along	cold	fly	idea	no	see	to	years
always	come	follow	into	noise	seven	today	yellow
and	could	food	is	nothing	shall	together	you
animal	country	for	kinds	now	she	too	young
are	covers	four	know	of	should	took	your
around	cried	friend	large	off	show	toward	
away	different	friendship	laugh	old	sing	try	cheer
baby	do	full	learning	once	small	two	children
ball	does	funny	light	one	soil	under	hello
be	done	give	like	only	some	until	hundred
bear	don't	go	listen	open	sometimes	use	mind
beautiful	door	goes	little	or	soon	very	next
because	down	good	live	our	sorry	walk	other
been	draw	great	long	out	starts	want	says
before	earth	green	look	over	stories	warms	table
began	eat	ground	loudly	own	story	was	this
begins	eight	grow	loved	paper	studied	wash	
bird	enough	happy	make	party	sure	watch	
blue	even	have	many	people	surprised	water	
both	every	he	maybe	pictures	take	we	
boy	everyone	head	me	play	talk	were	
bring	eyes	hear	minute	please	teacher	what	
brothers	fall	heard	more	pull	the	where	

**Decoding skills taught to date:** short *a*; short *i*; closed syllables (CVC: short *a*, *i*); short *o*; short *u*; short *e*; closed syllables (CVC: short *o*, *u*, *e*); long *a* (CVCe); long *i* (CVCe); /k/ spelled *c*; /s/ spelled *c*; long *o* (CVCe); long *u* /yōō/ (CVCe); long *u* /ōō/ (CVCe); long *e* (CVCe); /g/ spelled *g*; /j/ spelled *g*, *dge*; blends with *r*; blends with *l*; blends with *s*; consonants; short vowels; /z/ spelled *s*; inflection -s; final consonants *ll*; possessives with 's; consonants *ck*; long *e* (*e*, *ee*); long *o* (*oa*, *ow*); final blend *nd*



# Stan's Sled



Stan smiles. He slides and speeds on his sled.



Stan has a sled.  
Stan's sled will not slide.





The spot is flat. Stan's sled is still stuck.



Stan sees a steep hill. The snow is slick. Now Stan's sled can slide.

# Granddad's Pond

## DECODABLE WORDS

Target Skill: final blend *nd*

and	Granddad's	lend	sandy
bent	hand	Mandy	spend
end	hands	pond	
Granddad	land	Randy	

## Previously Taught Skills

at	had	liked	pole	with
big	he	long	summer	
can	held	lots	that	
catch	in	me	then	
farm	is	my	us	
fish	jump	next	want	
fished	jumped	on	we	
got	just	path	went	

SKILLS APPLIED IN WORDS IN STORY: short *a*; short *i*; short *o*; short *u*; short *e*; CVC syllable pattern; long *i* (CVCe); long *o* (CVCe); /*g*/ spelled *g*; blends with *r*; blends with *s*; final blend *nd*; consonants; short vowels; /*z*/ spelled *s*; final blend *mp*, *xt*; digraph *th*; base words ending *-ed* /*t*/; digraphs *ch*, *tch*; digraph *sh*; long *e* (*e*, *ee*); compound words; *r*-controlled *ar*, *r*-controlled *er*, *ir* and *ur*; long *i* spelled *y*

## HIGH-FREQUENCY WORDS

a	into	said	to
house	of	the	you
l	one	they	your

© Houghton Mifflin Harcourt Publishing Company

final blend *nd*

BOOK 41

# Granddad's Pond



Houghton Mifflin Harcourt.  
The Learning Company™

**High-Frequency Words Taught to Date**

a	brown	family	help	most	pushed	the	where
about	buy	far	her	mother	put	their	who
above	by	father	here	my	read	there	why
across	call	few	high	myself	ready	these	window
after	car	field	hold	near	right	they	with
again	carry	find	house	never	said	think	work
all	caught	first	how	new	school	those	world
almost	city	five	I	night	second	thought	would
along	cold	fly	idea	no	see	three	write
always	come	follow	into	noise	seven	to	years
and	could	food	is	nothing	shall	today	yellow
animal	country	for	kinds	now	she	together	you
are	covers	four	know	of	should	too	young
around	cried	friend	large	off	show	took	your
away	different	friendship	laugh	old	sing	toward	
baby	do	full	learning	once	small	try	cheer
ball	does	funny	light	one	soil	two	children
be	done	give	like	only	some	under	hello
bear	don't	go	listen	open	some-	until	hundred
beautiful	door	goes	little	or	times	use	mind
because	down	good	live	our	soon	very	next
been	draw	great	long	out	sorry	walk	other
before	earth	green	look	over	starts	want	says
began	eat	ground	loudly	own	stories	warms	sleep
begins	eight	grow	loved	paper	story	was	table
bird	enough	happy	make	party	studied	wash	this
blue	even	have	many	people	sure	watch	
both	every	he	maybe	pictures	surprised	water	
boy	everyone	head	me	play	take	we	
bring	eyes	hear	minute	please	talk	were	
brothers	fall	heard	more	pull	teacher	what	

**Decoding skills taught to date:** short *a*; short *i*; closed syllables (CVC: short *a*, *i*); short *o*; short *u*; short *e*; closed syllables (CVC: short *o*, *u*, *e*); long *a* (CVC*e*); long *i* (CVC*e*); /k/ spelled *c*; /s/ spelled *c*; long *o* (CVC*e*); long *u* /yōō/ (CVC*e*); long *u* /ōō/ (CVC*e*); long *e* (CVC*e*); /g/ spelled *g*; /j/ spelled *g*, *dge*; blends with *r*; blends with *l*; blends with *s*; final blend *nd*



Mandy and Randy held Granddad's hands. Granddad said, "Jump in!" Then Mandy and Randy and Granddad jumped in!

At the end of summer, Mandy and Randy said, "Granddad, we want to spend next summer at your pond!"

# Granddad's Pond



Mandy and Randy liked to spend summer with Granddad. He had a big house on a farm with lots of land. Granddad's land had a big pond!



Granddad, Mandy, and Randy went to the big pond. They went to the pond on a long, sandy path. "The pond is just at the end of that bend," said Granddad.



At the pond, Granddad said, "We can catch fish." Granddad and Mandy fished.

"I got a big one!" said Mandy. "My pole is bent! Can you lend me a hand, Granddad?"

# Stand and Mend

## DECODABLE WORDS

<b>Target Skill:</b>	<b>final blend <i>nd</i></b>		
and	hand	mend	strands
blond	hands	sand	wind
find	lend	stand	

## Previously Taught Skills

can	have	men	nets	whips
cut	in	must	rock	with
fishing	man	net	then	yells
get				

SKILLS APPLIED IN WORDS IN STORY: short *a*; short *i*; closed syllables (CVC: short *a*, *i*); short *o*; short *u*; short *e*; closed syllables (CVC: short *o*, *u*, *e*); blends with *r*; blends with *l*; blends with *s*; final blend *nd*; consonants; short vowels; digraph *sh*; digraph *th*; digraph *wh*; inflection *-s*; ending *-ing*; long *i* (CV)

## HIGH-FREQUENCY WORDS

a	their
the	these

© Houghton Mifflin Harcourt Publishing Company

final blend *nd*

**BOOK 42**

# Stand and Mend

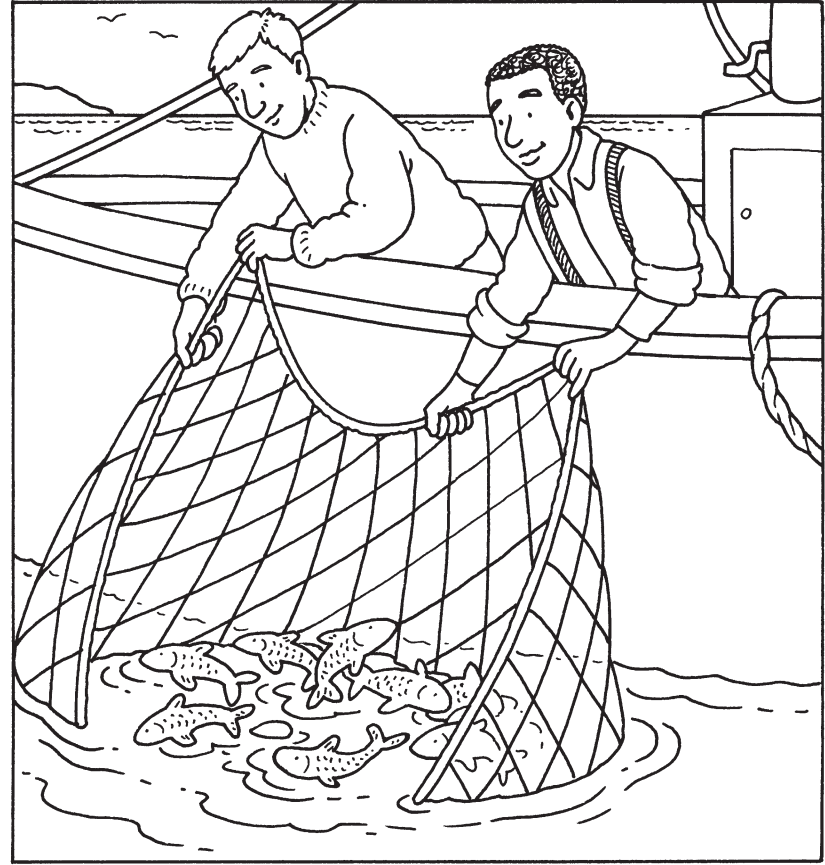

**High-Frequency Words Taught to Date**

a	brown	family	help	most	pushed	their	who
about	buy	far	her	mother	put	there	why
above	by	father	here	my	read	these	window
across	call	few	high	myself	ready	they	with
after	car	field	hold	near	right	think	work
again	carry	find	house	never	said	those	world
all	caught	first	how	new	school	thought	would
almost	city	five	I	night	second	three	write
along	cold	fly	idea	no	see	to	years
always	come	follow	into	noise	seven	today	yellow
and	could	food	is	nothing	shall	together	you
animal	country	for	kinds	now	she	too	young
are	covers	four	know	of	should	took	your
around	cried	friend	large	off	show	toward	
away	different	friendship	laugh	old	sing	try	cheer
baby	do	full	learning	once	small	two	children
ball	does	funny	light	one	soil	under	hello
be	done	give	like	only	some	until	hundred
bear	don't	go	listen	open	sometimes	use	mind
beautiful	door	goes	little	or	soon	very	next
because	down	good	live	our	sorry	walk	other
been	draw	great	long	out	starts	want	says
before	earth	green	look	over	stories	warms	sleep
began	eat	ground	loudly	own	story	was	table
begins	eight	grow	loved	paper	studied	wash	this
bird	enough	happy	make	party	sure	watch	
blue	even	have	many	people	surprised	water	
both	every	he	maybe	pictures	take	we	
boy	everyone	head	me	play	talk	were	
bring	eyes	hear	minute	please	teacher	what	
brothers	fall	heard	more	pull	the	where	

**Decoding skills taught to date:** short *a*; short *i*; closed syllables (CVC: short *a*, *i*); short *o*; short *u*; short *e*; closed syllables (CVC: short *o*, *u*, *e*); long *a* (CVCe); long *i* (CVCe); /k/ spelled *c*; /s/ spelled *c*; long *o* (CVCe); long *u* /yōō/ (CVCe); long *u* /ūū/ (CVCe); long *e* (CVCe); /g/ spelled *g*; /j/ spelled *g*, *dge*; blends with *r*; blends with *l*; blends with *s*; final blend *nd*



# Stand and Mend

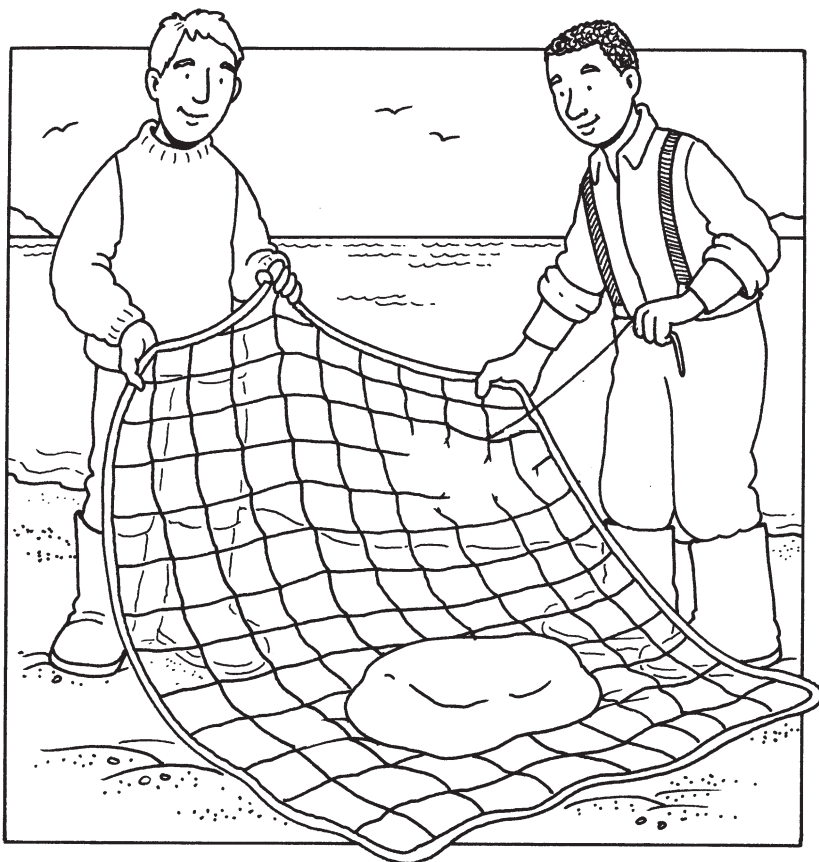

The men get the net and find a rock.  
Then the men can stand in the wind and  
mend, mend, mend.



These men stand in the sand and  
mend fishing nets.

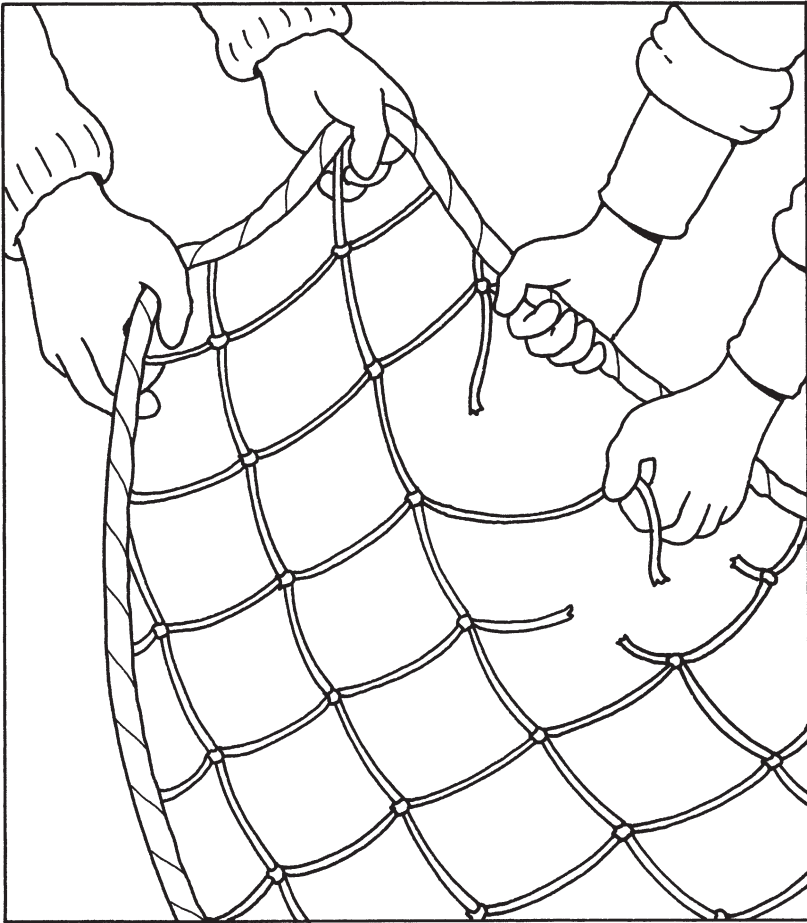

Nets can have cut strands. The men must mend cut strands with their hands.

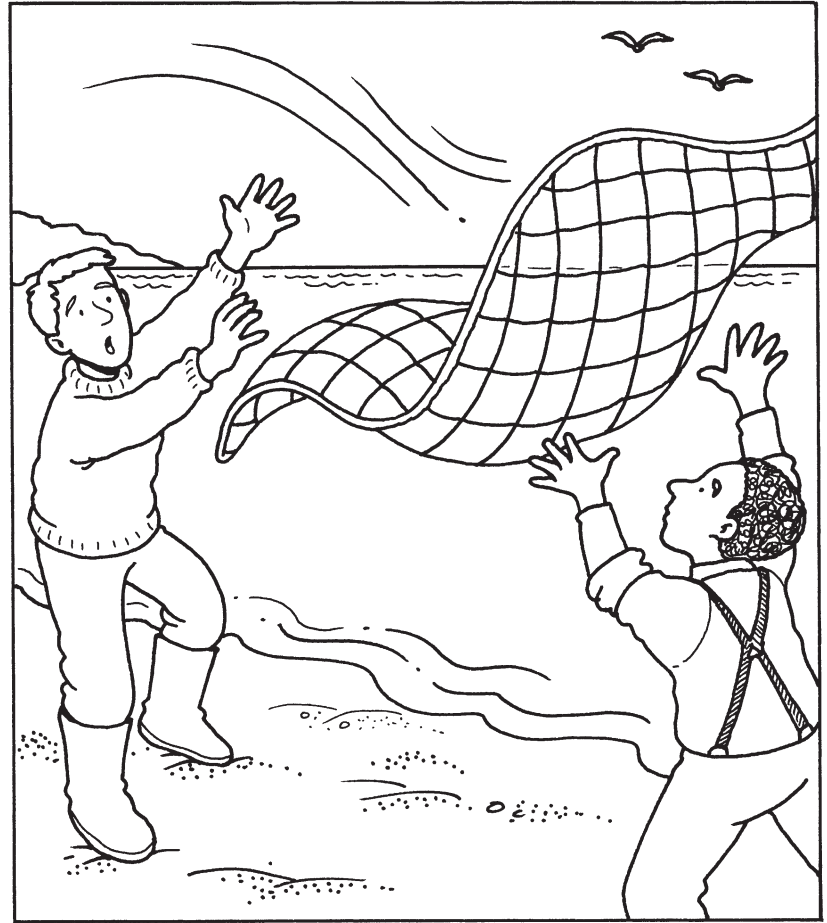

Wind whips the net.  
"Lend a hand!" yells the blond man.

# Pang Wong's Loud House

## DECODABLE WORDS

Target Skill: final blend *ng*

bong(s)	gong	Pang	songbird
bring	Ling	sing	Wong
clang(s)	Ming	song(s)	Wong's

## Previously Taught Skills

and	he	next	that
back	hear	not	then
can	hit	now	this
Chin	home	or	took
cooking	house	pans	went
cooks	is	see	when
day	it	she	wife
did	loud	smiled	will
filled	makes	sound	wise
for	me	take	with

SKILLS APPLIED IN WORDS IN STORY: short *a*; short *i*; CVC syllable pattern; short *e*; long *a* (CVC); long *i* (CVC); /k/ spelled *c*; blends with *r*; blends with *s*; final blend *nd*; final blend *ng*; consonants; short vowels; /z/ spelled *s*; double consonants *ll*; consonants *-ck*; final blend *-nt*; base words ending *-s*; base words ending *-ed* /d/; base words ending *-ing*; digraphs *th*, *ch*, *sh*, *wh*; long *e* (*e*, *ee*); long *e* (*ea*, *e\_e*); compound words; *r*-controlled *or* and *ore*; vowel digraphs *oo* /ōō/; vowel combinations *ou*, *ow*; long *e* spelled *y*; long *a* (*ay*); long *o* (CV)

## HIGH-FREQUENCY WORDS

a	of	the	what
do	only	to	you
I	said	too	your
my	so	was	

© Houghton Mifflin Harcourt Publishing Company

final blend *ng*

BOOK 43

# Pang Wong's Loud House

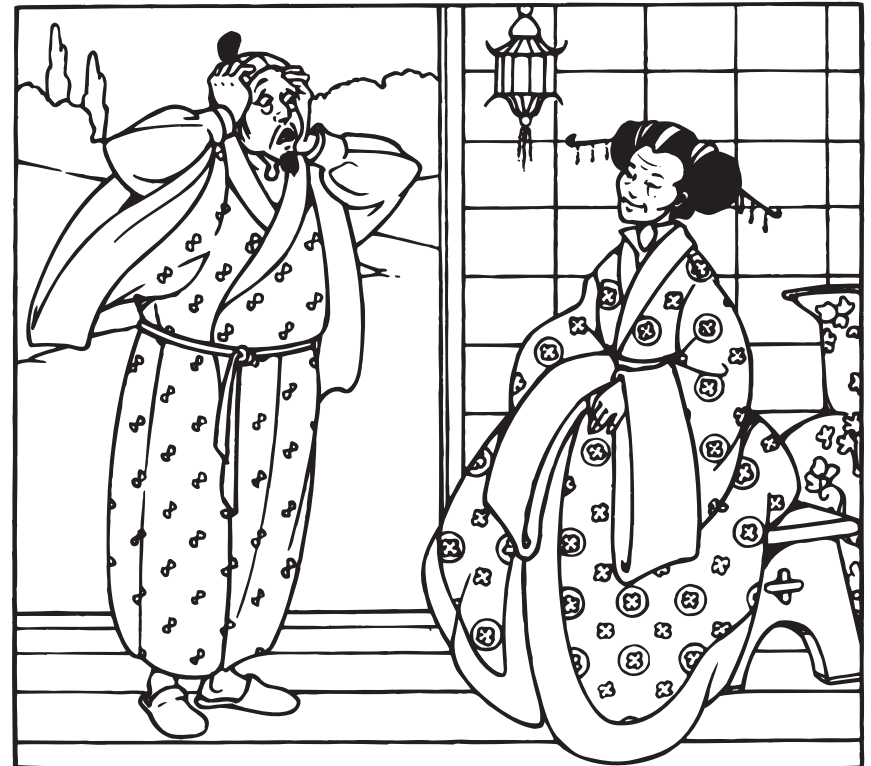

Houghton Mifflin Harcourt.  
The Learning Company™

**High-Frequency Words Taught to Date**

a	brown	family	help	most	pushed	their	who
about	buy	far	her	mother	put	there	why
above	by	father	here	my	read	these	window
across	call	few	high	myself	ready	they	with
after	car	field	hold	near	right	think	work
again	carry	find	house	never	said	those	world
all	caught	first	how	new	school	thought	would
almost	city	five	I	night	second	three	write
along	cold	fly	idea	no	see	to	years
always	come	follow	into	noise	seven	today	yellow
and	could	food	is	nothing	shall	together	you
animal	country	for	kinds	now	she	too	young
are	covers	four	know	of	should	took	your
around	cried	friend	large	off	show	toward	
away	different	friendship	laugh	old	sing	try	cheer
baby	do	full	learning	once	small	two	children
ball	does	funny	light	one	soil	under	hello
be	done	give	like	only	some	until	hundred
bear	don't	go	listen	open	sometimes	use	mind
beautiful	door	goes	little	or	soon	very	next
because	down	good	live	our	sorry	walk	other
been	draw	great	long	out	starts	want	says
before	earth	green	look	over	stories	warms	sleep
began	eat	ground	loudly	own	story	was	table
begins	eight	grow	loved	paper	studied	wash	this
bird	enough	happy	make	party	sure	watch	
blue	even	have	many	people	surprised	water	
both	every	he	maybe	pictures	take	we	
boy	everyone	head	me	play	talk	were	
bring	eyes	hear	minute	please	teacher	what	
brothers	fall	heard	more	pull	the	where	

**Decoding skills taught to date:** short *a*; short *i*; closed syllables (CVC: short *a*, *i*); short *o*; short *u*; short *e*; closed syllables (CVC: short *o*, *u*, *e*); long *a* (CVCe); long *i* (CVCe); /k/ spelled *c*; /s/ spelled *c*; long *o* (CVCe); long *u* /yōō/ (CVCe); long *u* /ōō/ (CVCe); long *e* (CVCe); /g/ spelled *g*; /j/ spelled *g*, *dge*; blends with *r*; blends with *t*; blends with *s*; final blend *nd*; final blend *ng*



Pang Wong took the gong and the songbird back to Wise Ming Chin. Then he went home. He did not hear gong bongs or songbird songs. The only sound was the clang of cooking pans. Ling Wong smiled and said, "Pang Wong, now your house is not so loud!"

## Pang Wong's Loud House

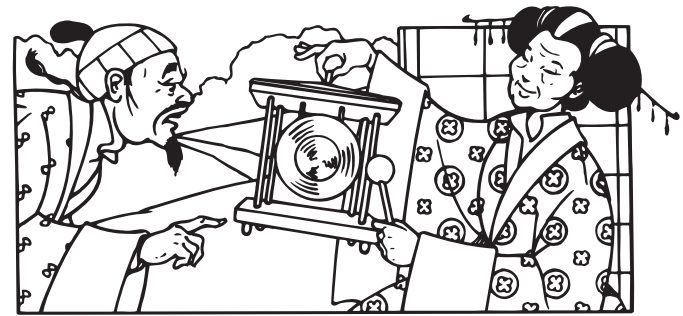

Pang Wong went to see Wise Ming Chin. He said, "Wise Ming Chin, my house is too loud. My wife, Ling Wong, clangs the pans when she cooks. What can I do?"

Wise Ming Chin smiled and said, "Take this gong to your house. Hit it so that it makes a loud bong."



The next day, Pang Wong went back to Wise Ming Chin. He said, "Wise Ming Chin! Now my house is filled with pan clangs and gong bongs. It is too loud! What can I do?"

Wise Ming Chin smiled and said, "Take this songbird to your house. It will sing a song for you."

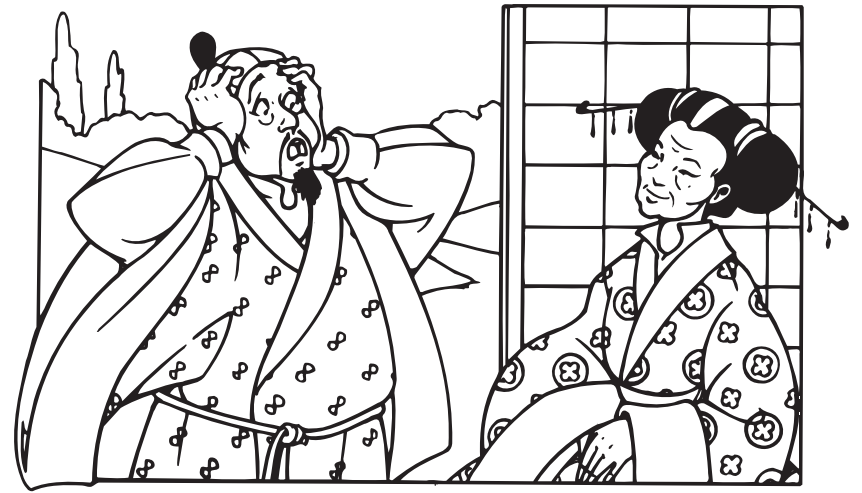

The next day, Pang Wong went back to Wise Ming Chin. He said, "Now my house is filled with pan clangs, gong bongs, and songbird songs. It is too loud! What can I do?"

Wise Ming Chin smiled and said, "Bring the gong and songbird back to me, Pang Wong."

# A Big Gong

## DECODABLE WORDS

Target Skill: final blend *ng*

Bing	bring	King	ring	sing
bong	gong	rang	sang	songs

Previously Taught Skills

am	dad	is	not	will
and	did	man	sleeps	
bed	dreams	me	still	
bells	hit	Meg	up	
big	in	Meg's	wake	

SKILLS APPLIED IN WORDS IN STORY: short *a*; short *i*; closed syllables (CVC: short *a*, *i*); short *o*; short *u*; short *e*; closed syllables (CVC: short *o*, *u*, *e*); long *a* (CVCe); /g/ spelled *g*; blends with *r*; blends with *l*; blends with *s*; final blend *ng*; consonants; short vowels; possessives with 's; long vowel spelling patterns for *a*, *e*, *i*, *o*, *u*

## HIGH-FREQUENCY WORDS

a	near	the
I	said	

# A Big Gong

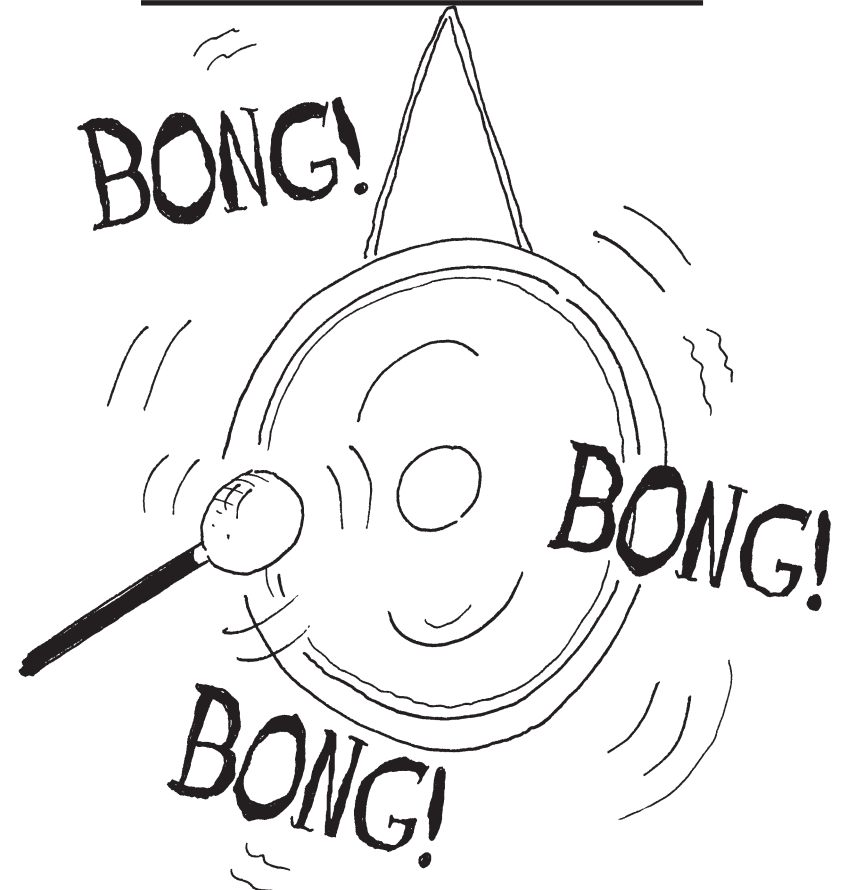



**High-Frequency Words Taught to Date**

a	brown	family	help	most	pushed	their	who
about	buy	far	her	mother	put	there	why
above	by	father	here	my	read	these	window
across	call	few	high	myself	ready	they	with
after	car	field	hold	near	right	think	work
again	carry	find	house	never	said	those	world
all	caught	first	how	new	school	thought	would
almost	city	five	I	night	second	three	write
along	cold	fly	idea	no	see	to	years
always	come	follow	into	noise	seven	today	yellow
and	could	food	is	nothing	shall	together	you
animal	country	for	kinds	now	she	too	young
are	covers	four	know	of	should	took	your
around	cried	friend	large	off	show	toward	
away	different	friendship	laugh	old	sing	try	cheer
baby	do	full	learning	once	small	two	children
ball	does	funny	light	one	soil	under	hello
be	done	give	like	only	some	until	hundred
bear	don't	go	listen	open	sometimes	use	mind
beautiful	door	goes	little	or	soon	very	next
because	down	good	live	our	sorry	walk	other
been	draw	great	long	out	starts	want	says
before	earth	green	look	over	stories	warms	sleep
began	eat	ground	loudly	own	story	was	table
begins	eight	grow	loved	paper	studied	wash	this
bird	enough	happy	make	party	sure	watch	
blue	even	have	many	people	surprised	water	
both	every	he	maybe	pictures	take	we	
boy	everyone	head	me	play	talk	were	
bring	eyes	hear	minute	please	teacher	what	
brothers	fall	heard	more	pull	the	where	

**Decoding skills taught to date:** short *a*; short *i*; closed syllables (CVC: short *a*, *i*); short *o*; short *u*; short *e*; closed syllables (CVC: short *o*, *u*, *e*); long *a* (CVCe); long *i* (CVCe); /k/ spelled *c*; /s/ spelled *c*; long *o* (CVCe); long *u* /yōō/ (CVCe); long *u* /ōō/ (CVCe); long *e* (CVCe); /g/ spelled *g*; /j/ spelled *g*, *dge*; blends with *r*; blends with *l*; blends with *s*; final blend *nd*; final blend *ng*

# A Big Gong



Meg is in bed. Meg sleeps and dreams. Meg's dad is King Bing.

"Wake up!" said King Bing. Meg did not wake up.



King Bing hit the gong.  
BONG! BONG! BONG!

"I am up! I am up, Dad!" said Meg.



"Ring bells! Sing songs!" said King Bing. A man near the king rang bells and sang songs. Meg still did not wake up.



"Meg will not wake up!" said King Bing.  
"Bring me the big gong!"

# The Hidden Trunk

## DECODABLE WORDS

Target Skill: final blend *nk*

bank	Franklin	pink	trunk
blink	hanky	sink	trunk's
clank	junk	thanks	yanked
dank	mink	think	

## Previously Taught Skills

an	dusty	hat	made	stuff
and	empty	he	map	tell
basement	found	hidden	new	these
big	fun	in	nice	things
born	game	is	not	this
dad	gave	it	puff	up
dark	Gran	just	she	will
down	Granddad	lid	shut	with
dust	had	loud	sit	you

SKILLS APPLIED IN WORDS IN STORY: short *a*; short *i*; CVC syllable pattern (closed syllables); short *o*; short *u*; short *e*; long *a* (CVCe); /k/ spelled *c*; long *o* (CVCe); blends with *r*; blends with *l*; blends with *s*; final blend *nd*; final blend *nk*; consonant sounds; /z/ spelled *s*; double final consonants *ff*, *ll*; final blend *nt*; digraphs *sh*, *th*; base words and ending *-ed* /d/, /t/; base words and ending *-ing*; possessives with 's; long *e* (*e*, *ee*); ong *e* (*ea*, *e\_e*); *r*-controlled *ar*, *or*; vowel digraph *oo* /ōō/; vowel digraph /ōō/ spelled *oo*, *ou*, *ew*; vowel combinations *ou*, *ow*; long *e* spelled *y*

## HIGH-FREQUENCY WORDS

a	for	old	was
about	I	said	were
before	long	story	what
do	of	the	your

© Houghton Mifflin Harcourt Publishing Company

final blend *nk*

BOOK 45

# The Hidden Trunk

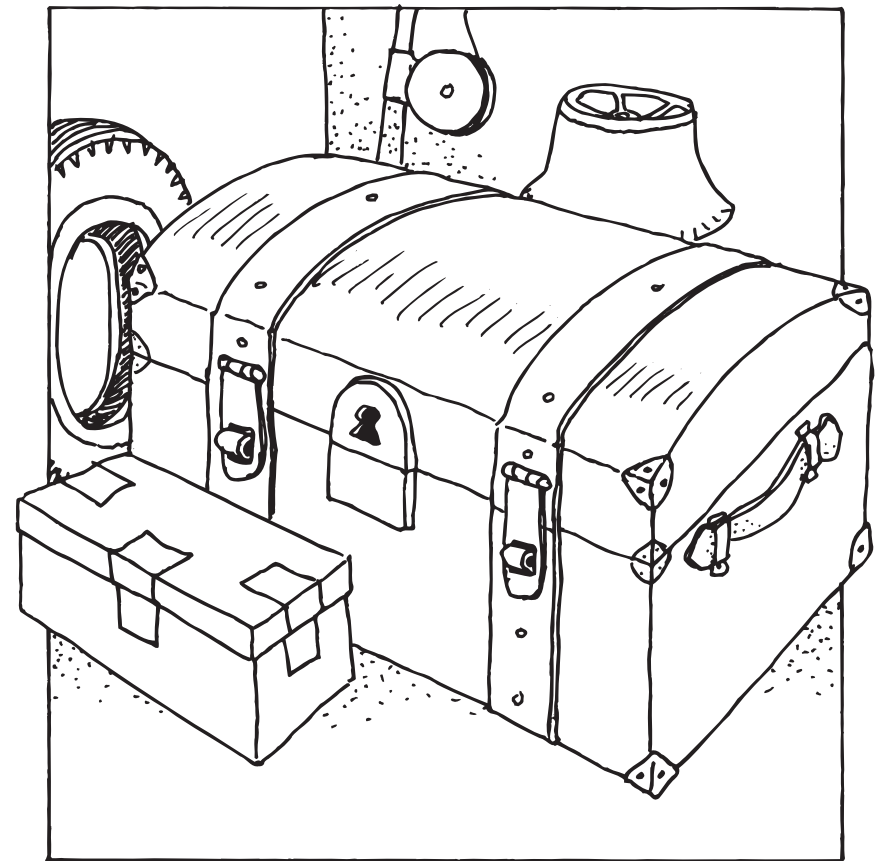

Houghton Mifflin Harcourt.  
The Learning Company™

**High-Frequency Words Taught to Date**

a	brown	family	help	most	pushed	the	where
about	buy	far	her	mother	put	their	who
above	by	father	here	my	read	there	why
across	call	few	high	myself	ready	these	window
after	car	field	hold	near	right	they	with
again	carry	find	house	never	said	think	work
all	caught	first	how	new	school	those	world
almost	city	five	I	night	second	thought	would
along	cold	fly	idea	no	see	three	write
always	come	follow	into	noise	seven	to	years
and	could	food	is	nothing	shall	today	yellow
animal	country	for	kinds	now	she	together	you
are	covers	four	know	of	should	too	young
around	cried	friend	large	off	show	took	your
away	different	friendship	laugh	old	sing	toward	
baby	do	full	learning	once	small	try	cheer
ball	does	funny	light	one	soil	two	children
be	done	give	like	only	some	under	hello
bear	don't	go	listen	open	some-	until	hundred
beautiful	door	goes	little	or	times	use	mind
because	down	good	live	our	soon	very	next
been	draw	great	long	out	sorry	walk	other
before	earth	green	look	over	starts	want	says
began	eat	ground	loudly	own	stories	warms	sleep
begins	eight	grow	loved	paper	story	was	table
bird	enough	happy	make	party	studied	wash	this
blue	even	have	many	people	sure	watch	
both	every	he	maybe	pictures	surprised	water	
boy	everyone	head	me	play	take	we	
bring	eyes	hear	minute	please	talk	were	
brothers	fall	heard	more	pull	teacher	what	

**Decoding skills taught to date:** short *a*; short *i*; CVC syllable pattern (closed syllables); short *o*; short *u*; short *e*; long *a* (CVCe); long *i* (CVCe); /k/ spelled *c*; /s/ spelled *c*; long *o* (CVCe); long *u* /yōō/ (CVCe); long *u* /ōō/ (CVCe); long *e* (CVCe); /g/ spelled *g*; /j/ spelled *g*, *dge*; blends with *r*; blends with *l*; blends with *s*; final blend *nd*; final blend *ng*; final blend *nk*

# The Hidden Trunk



Gran made up a fun new game. She gave Franklin a map. It had an "X."

"Find my hidden trunk, Franklin," said Gran. "Use the map."

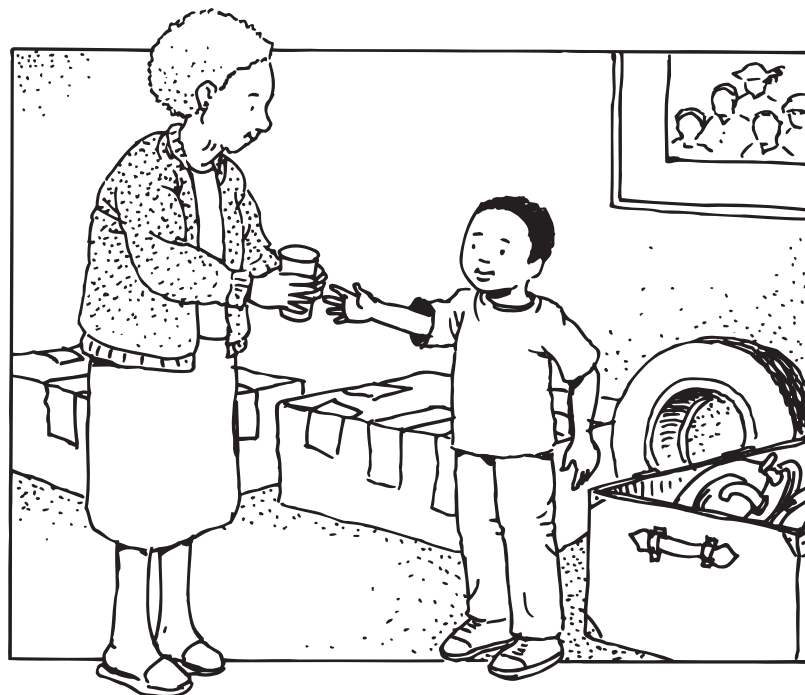

"Franklin!" said Gran. "This stuff is not junk. Granddad and I had these things before your dad was born. Sit down, and I will tell you about this trunk."

"Nice! Thanks!" said Franklin.



Franklin found the trunk in the dark, dank basement. He yanked the trunk's lid. It made a loud clank. A puff of dust made Franklin blink.

What do you think Franklin found?

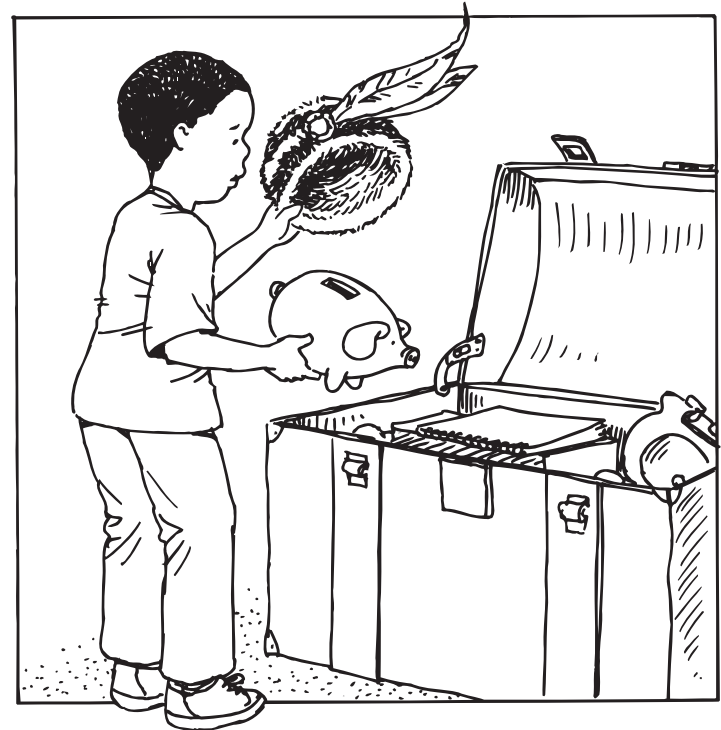

He found a pink hanky, an empty bank, a dusty mink hat, and an old sink. Franklin shut the trunk lid with a big clank. "This stuff is just junk," he said.



# Thanks, Frank!

## DECODABLE WORDS

**Target Skill:** final blend *nk*

blank	Hank	tank	thanks
Frank	ink	thank	trunk

## Previously Taught Skills

and	got	then
fish	left	this
gave	page	will

SKILLS APPLIED IN WORDS IN STORY: short *a*; short *i*; closed syllables (CVC: short *a*, *i*); short *o*; short *u*; short *e*; closed syllables (CVC: short *o*, *u*, *e*); long *a* (CV*Ce*); /*g*/ spelled *g*; /*j*/ spelled *g*, *dge*; blends with *r*; blends with *l*; consonants; short vowels; /*z*/ spelled *s*; inflection *-s*; final consonants *ll*; digraph *th*; long *e* (*e*, *ee*)

## HIGH-FREQUENCY WORDS

a	I	some	your
for	paper	the	
friend	said	you	

© Houghton Mifflin Harcourt Publishing Company

final blend *nk*

**BOOK 46**

# Thanks, Frank!

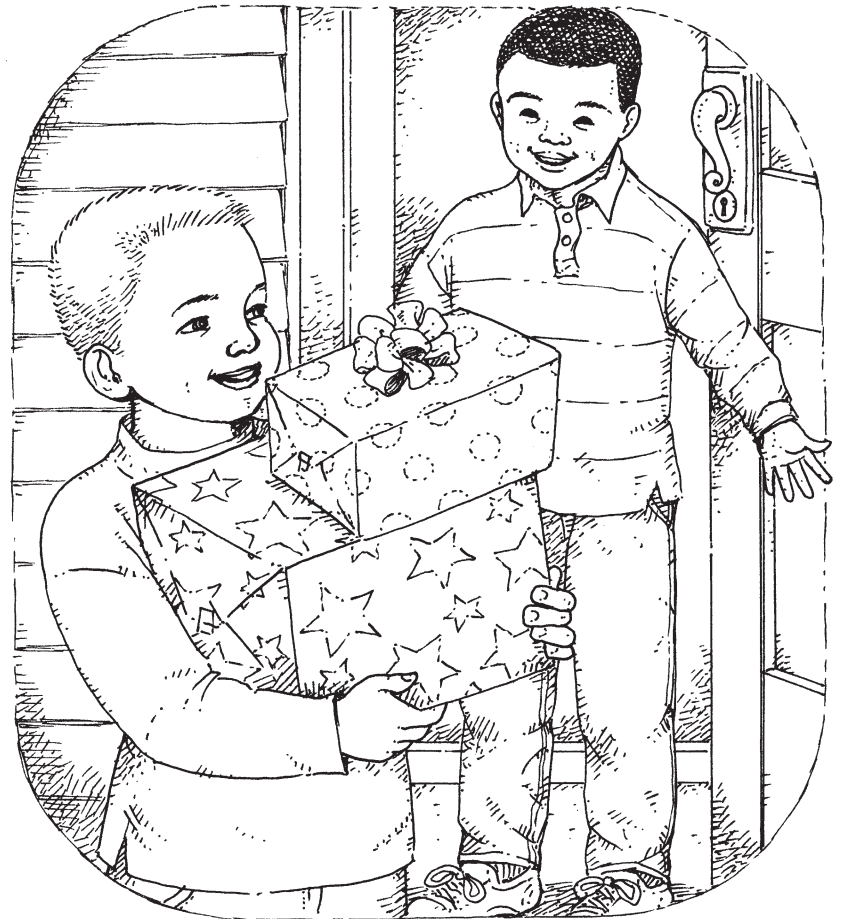

**High-Frequency Words Taught to Date**

a	brown	family	help	most	pushed	their	who
about	buy	far	her	mother	put	there	why
above	by	father	here	my	read	these	window
across	call	few	high	myself	ready	they	with
after	car	field	hold	near	right	think	work
again	carry	find	house	never	said	those	world
all	caught	first	how	new	school	thought	would
almost	city	five	I	night	second	three	write
along	cold	fly	idea	no	see	to	years
always	come	follow	into	noise	seven	today	yellow
and	could	food	is	nothing	shall	together	you
animal	country	for	kinds	now	she	too	young
are	covers	four	know	of	should	took	your
around	cried	friend	large	off	show	toward	
away	different	friendship	laugh	old	sing	try	cheer
baby	do	full	learning	once	small	two	children
ball	does	funny	light	one	soil	under	hello
be	done	give	like	only	some	until	hundred
bear	don't	go	listen	open	sometimes	use	mind
beautiful	door	goes	little	or	soon	very	next
because	down	good	live	our	sorry	walk	other
been	draw	great	long	out	starts	want	says
before	earth	green	look	over	stories	warms	sleep
began	eat	ground	loudly	own	story	was	table
begins	eight	grow	loved	paper	studied	wash	this
bird	enough	happy	make	party	sure	watch	
blue	even	have	many	people	surprised	water	
both	every	he	maybe	pictures	take	we	
boy	everyone	head	me	play	talk	were	
bring	eyes	hear	minute	please	teacher	what	
brothers	fall	heard	more	pull	the	where	

**Decoding skills taught to date:** short *a*; short *i*; closed syllables (CVC: short *a*, *i*); short *o*; short *u*; short *e*; closed syllables (CVC: short *o*, *u*, *e*); long *a* (CVCe); long *i* (CVCe); /k/ spelled *c*; /s/ spelled *c*; long *o* (CVCe); long *u* /yōō/ (CVCe); long *u* /ōō/ (CVCe); long *e* (CVCe); /g/ spelled *g*; /j/ spelled *g*, *dge*; blends with *r*; blends with *l*; blends with *s*; final blend *nd*; final blend *ng*; final blend *nk*

# Thanks, Frank!

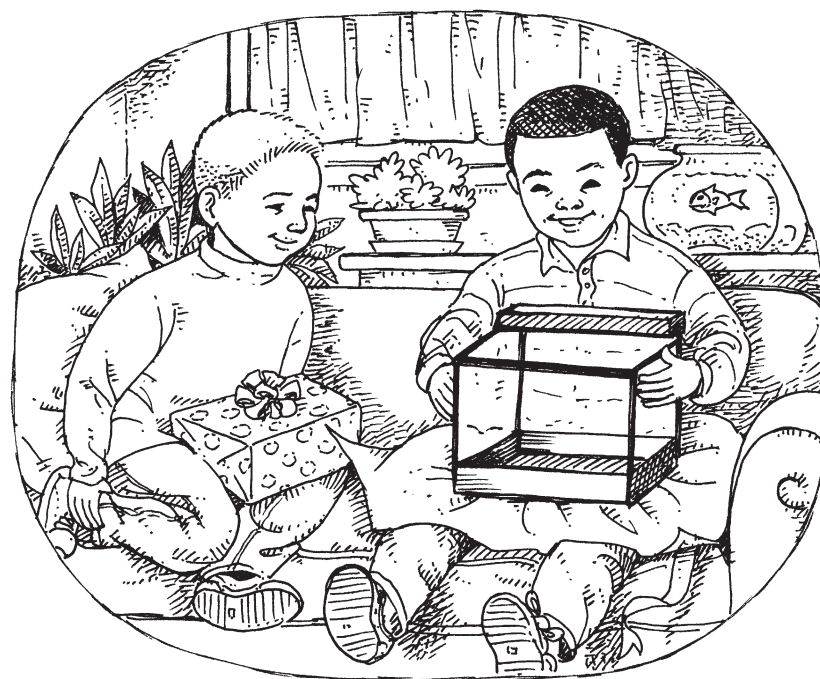

Frank gave Hank a fish tank.  
“Thanks, Frank!” said Hank.

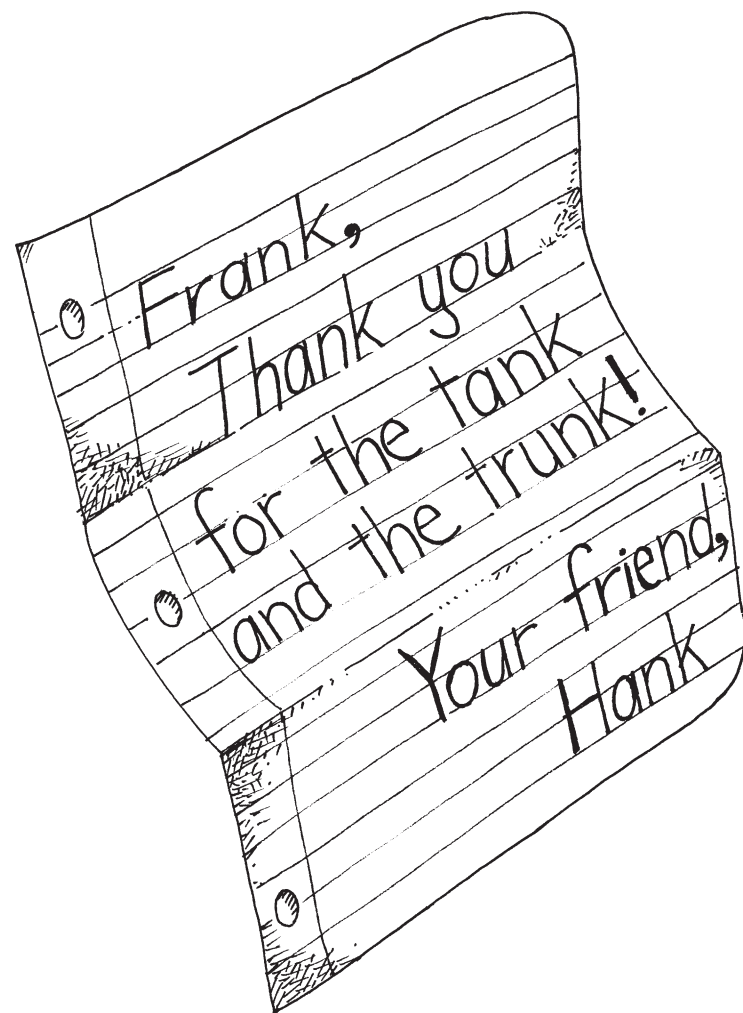

Hank gave Frank this page. “Thanks, Hank!” said Frank.

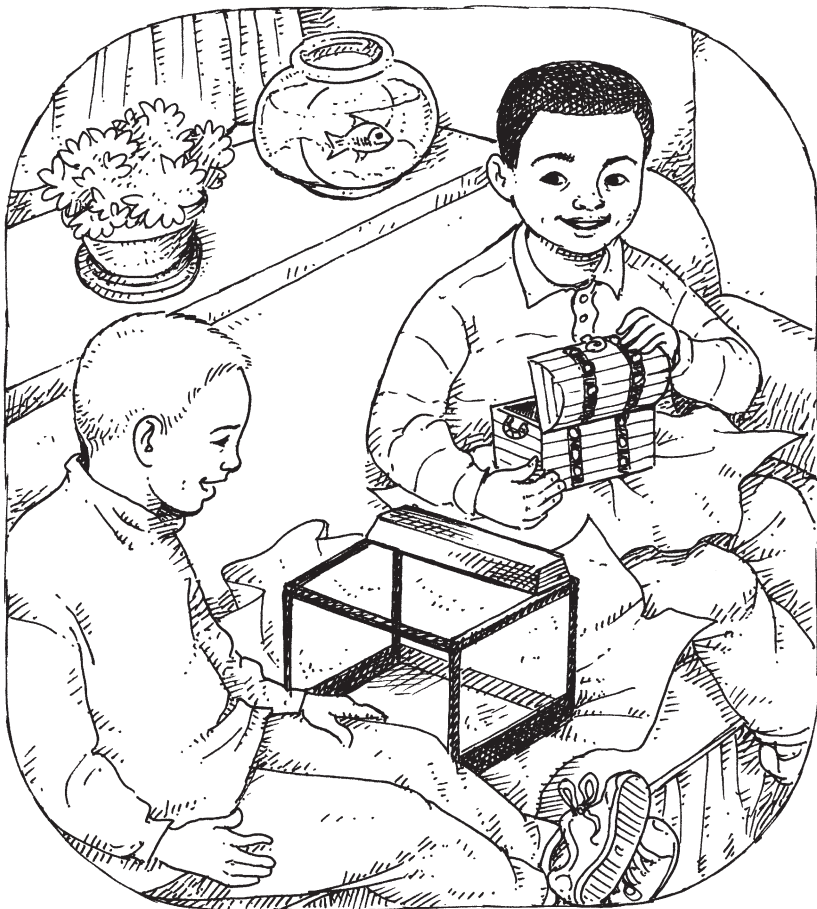

Frank gave Hank a trunk.  
"Thanks, Frank!" said Hank.



Then Frank left. Hank got some ink and  
blank paper.  
"I will thank Frank," said Hank.

## Trent Pretends

### DECODABLE WORDS

Target Skill: final blend *nt*

dentist	paints	pretends	Trent
glint	pretend	tent	

### Previously Taught Skills

an	camp	is	smiles
and	days	makes	wet
art	his	must	with
artist	home	on	
camper	in	smile	

SKILLS APPLIED IN WORDS IN STORY: short *a*; short *i*; CVC syllable pattern (closed syllables); short *o*; short *u*; short *e*; long *a* (CVCe); long *i* (CVCe); /k/ spelled *c*; /g/ spelled *g*; blends with *r*; blends with *s*; blends with *l*; final blend *nd*; final blend *nt*; consonants; short vowels; *r*-controlled *ar*; base words and ending *er*; base words and inflection *er*

### HIGH-FREQUENCY WORDS

a	great	like	sure
does	he	play	to

© Houghton Mifflin Harcourt Publishing Company

final blend *nt*

**BOOK 47**

# Trent Pretends



**High-Frequency Words Taught to Date**

a	brown	family	help	most	pushed	their	who
about	buy	far	her	mother	put	there	why
above	by	father	here	my	read	these	window
across	call	few	high	myself	ready	they	with
after	car	field	hold	near	right	think	work
again	carry	find	house	never	said	those	world
all	caught	first	how	new	school	thought	would
almost	city	five	I	night	second	three	write
along	cold	fly	idea	no	see	to	years
always	come	follow	into	noise	seven	today	yellow
and	could	food	is	nothing	shall	together	you
animal	country	for	kinds	now	she	too	young
are	covers	four	know	of	should	took	your
around	cried	friend	large	off	show	toward	
away	different	friendship	laugh	old	sing	try	cheer
baby	do	full	learning	once	small	two	children
ball	does	funny	light	one	soil	under	hello
be	done	give	like	only	some	until	hundred
bear	don't	go	listen	open	sometimes	use	mind
beautiful	door	goes	little	or	soon	very	next
because	down	good	live	our	sorry	walk	other
been	draw	great	long	out	starts	want	says
before	earth	green	look	over	stories	warms	sleep
began	eat	ground	loudly	own	story	was	table
begins	eight	grow	loved	paper	studied	wash	this
bird	enough	happy	make	party	sure	watch	
blue	even	have	many	people	surprised	water	
both	every	he	maybe	pictures	take	we	
boy	everyone	head	me	play	talk	were	
bring	eyes	hear	minute	please	teacher	what	
brothers	fall	heard	more	pull	the	where	

**Decoding skills taught to date:** short *a*; short *i*; closed syllables (CVC: short *a*, *l*); short *o*; short *u*; short *e*; closed syllables (CVC: short *o*, *u*, *e*); long *a* (CVCe); long *i* (CVCe); /k/ spelled *c*; /s/ spelled *c*; long *o* (CVCe); long *u* /yōō/ (CVCe); long *u* /ōō/ (CVCe); long *e* (CVCe); /g/ spelled *g*; /j/ spelled *g*, *dge*; blends with *r*; blends with *l*; blends with *s*; final blend *nd*; final blend *ng*; final blend *nk*; final blend *nt*; consonants; short vowels; *r*-controlled *ar*; base words and ending *er*; base words and inflection *er*





On wet days, Trent must play in his home. Trent is a camper, an artist, and a dentist.

Trent sure does like to pretend. He is great!



On wet days, Trent must play in his home. Trent pretends he is a camper. Trent makes a tent and camps.

Trent is a camper!





© Houghton Mifflin Harcourt Publishing Company

On wet days, Trent must play in his home. Trent pretends he is an artist. Trent makes art with paints. Trent is an artist!



On wet days, Trent must play in his home. Trent pretends he is a dentist. Trent makes smiles glint. Trent is a dentist!

# Ant Nest

## DECODABLE WORDS

Target Skill: final blend *nt*

ant	dent	mint	vent
ants	hunt	plant	

## Previously Taught Skills

back	fine	his	must	wide
big	has	is	nest	will
deep	he	make	queen	
drags	help	mend	this	

SKILLS APPLIED IN WORDS IN STORY: short *a*; short *i*; closed syllables (CVC: short *a*, *i*); short *u*; short *e*; closed syllables (CVC: short *o*, *u*, *e*); long *a* (CVCe); long *i* (CVCe); /g/ spelled *g*; blends with *l*; blends with *s*; final blend *nd*; final blend *nt*; consonants; short vowels; /z/ spelled *s*; inflection -s; /kw/ spelled *qu*; final consonants *ll*; digraph *th*; long *e* (*e*, *ee*)

## HIGH-FREQUENCY WORDS

a	their
the	to

© Houghton Mifflin Harcourt Publishing Company

final blend *nt*

**BOOK 48**

# Ant Nest

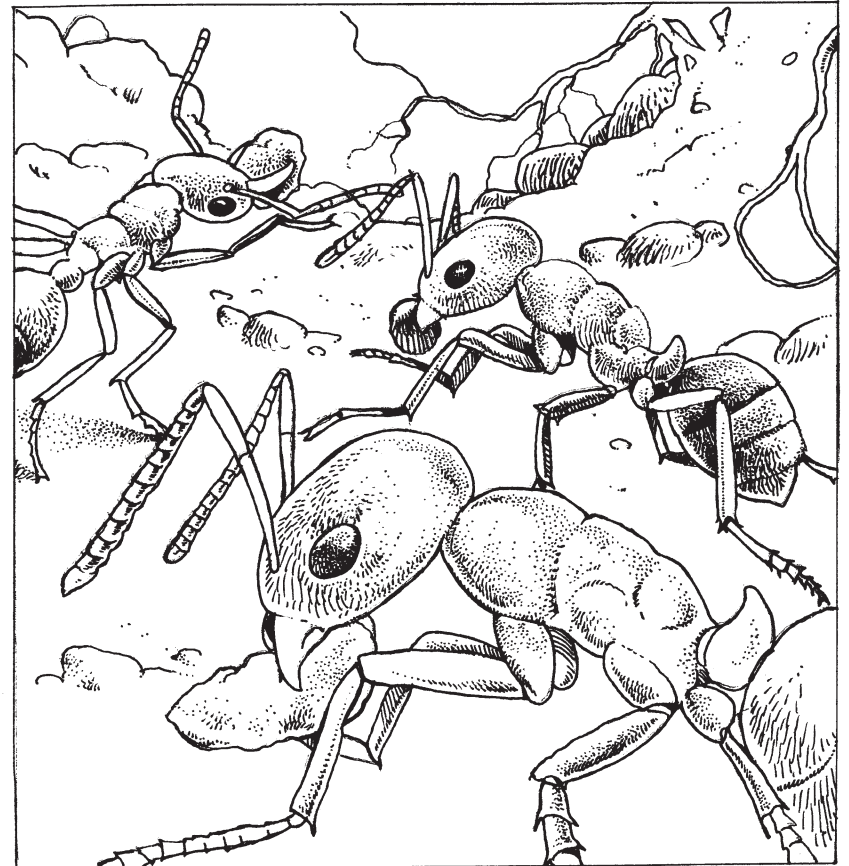

**High-Frequency Words Taught to Date**

a	brown	family	help	most	pushed	their	who
about	buy	far	her	mother	put	there	why
above	by	father	here	my	read	these	window
across	call	few	high	myself	ready	they	with
after	car	field	hold	near	right	think	work
again	carry	find	house	never	said	those	world
all	caught	first	how	new	school	thought	would
almost	city	five	I	night	second	three	write
along	cold	fly	idea	no	see	to	years
always	come	follow	into	noise	seven	today	yellow
and	could	food	is	nothing	shall	together	you
animal	country	for	kinds	now	she	too	young
are	covers	four	know	of	should	took	your
around	cried	friend	large	off	show	toward	
away	different	friendship	laugh	old	sing	try	cheer
baby	do	full	learning	once	small	two	children
ball	does	funny	light	one	soil	under	hello
be	done	give	like	only	some	until	hundred
bear	don't	go	listen	open	sometimes	use	mind
beautiful	door	goes	little	or	soon	very	next
because	down	good	live	our	sorry	walk	other
been	draw	great	long	out	starts	want	says
before	earth	green	look	over	stories	warms	sleep
began	eat	ground	loudly	own	story	was	table
begins	eight	grow	loved	paper	studied	wash	this
bird	enough	happy	make	party	sure	watch	
blue	even	have	many	people	surprised	water	
both	every	he	maybe	pictures	take	we	
boy	everyone	head	me	play	talk	were	
bring	eyes	hear	minute	please	teacher	what	
brothers	fall	heard	more	pull	the	where	

**Decoding skills taught to date:** short *a*; short *i*; closed syllables (CVC: short *a*, *i*); short *o*; short *u*; short *e*; closed syllables (CVC: short *o*, *u*, *e*); long *a* (CVCe); long *i* (CVCe); /k/ spelled *c*; /s/ spelled *c*; long *o* (CVCe); long *u* /yōō/ (CVCe); long *u* /ūū/ (CVCe); long *e* (CVCe); /g/ spelled *g*; /j/ spelled *g*, *dge*; blends with *r*; blends with *l*; blends with *s*; final blend *nd*; final blend *ng*; final blend *nk*; final blend *nt*

# Ant Nest

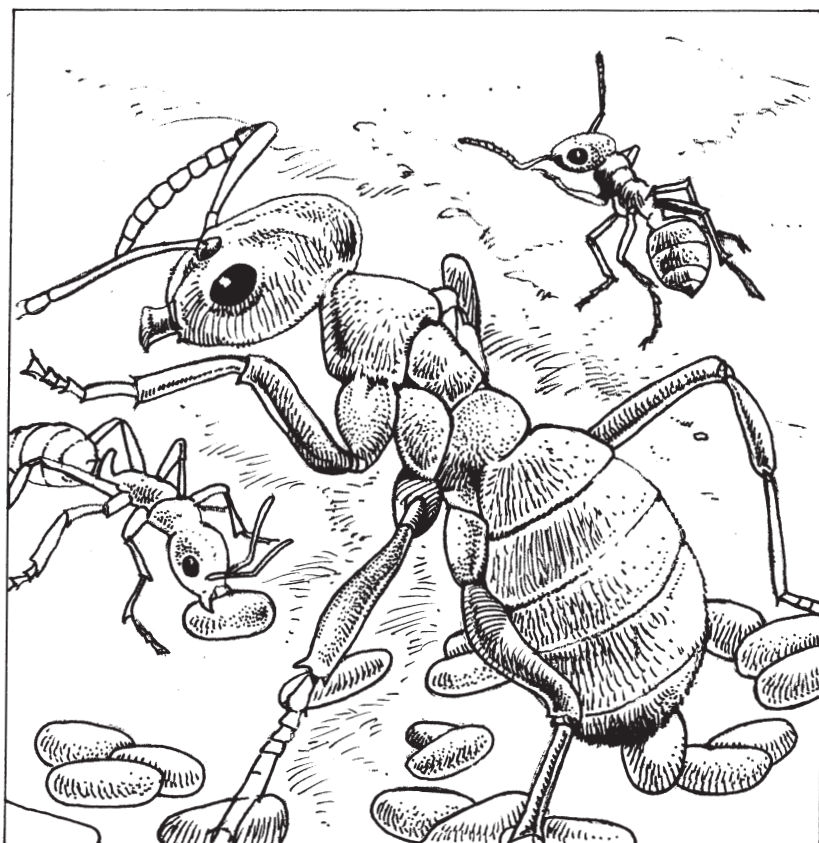

The queen ant is big. The ants must help their queen.



Ants make a big, deep nest. The nest has a wide vent.

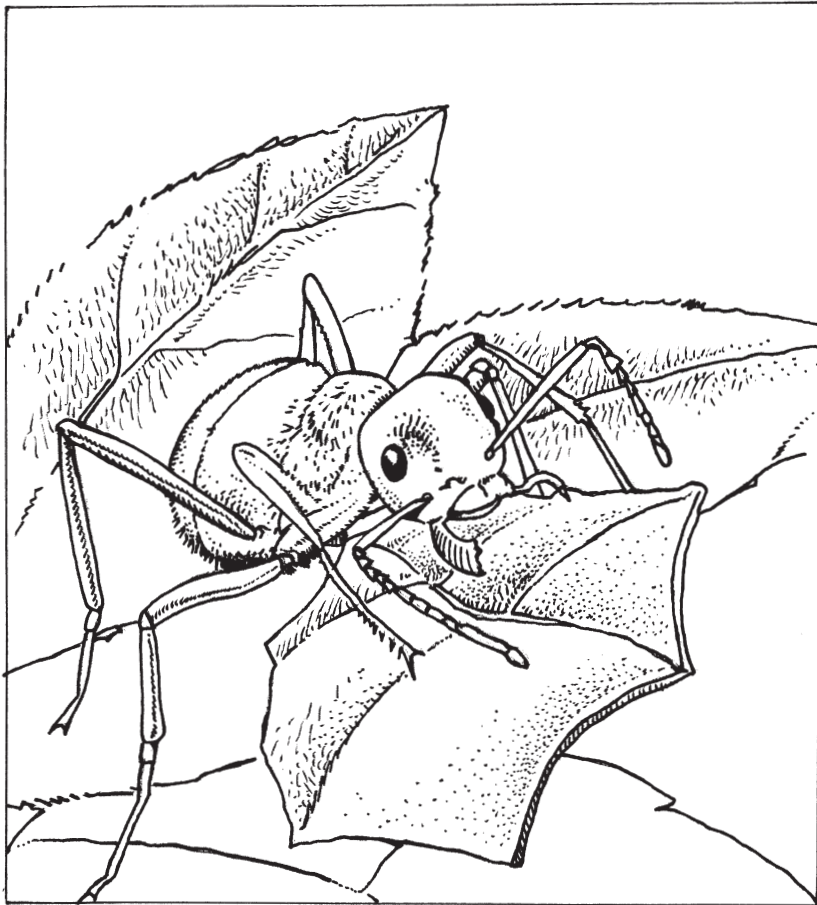

This ant will hunt. Hunt, ant, hunt!  
He drags a fine mint plant back to his  
nest.

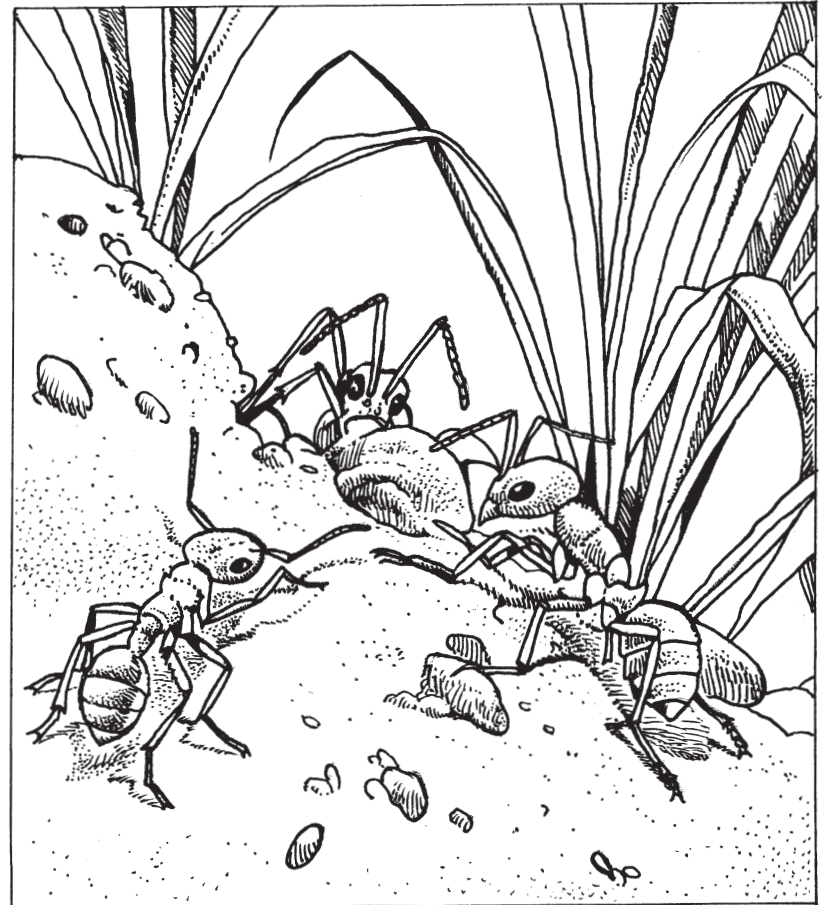

The nest has a big dent. Ants will  
mend the dent.



# Dell

## DECODABLE WORDS

Target Skill: double final consonants //

Dell	fell	sill	will
doll	Lill	well	

## Previously Taught Skills

and	fun	here	pal
bad	get	in	ran
bed	glad	is	
bump	got	not	
can	help	on	

SKILLS APPLIED IN WORDS IN STORY: short *a*; short *i*; closed syllables (CVC: short *a*, *i*); /k/ spelled *c*; short *o*; short *u*; short *e*; closed syllables (CVC: short *o*, *u*, *e*); long *e* (CVGe); /g/ spelled *g*; blends with *l*; final blend *nd*; double final consonants //; consonants; short vowels; /z/ spelled *s*; inflection -s; final blend *mp*

## HIGH-FREQUENCY WORDS

a	new	said	this
her	put	see	to
I	put(s)	that	you

# Dell

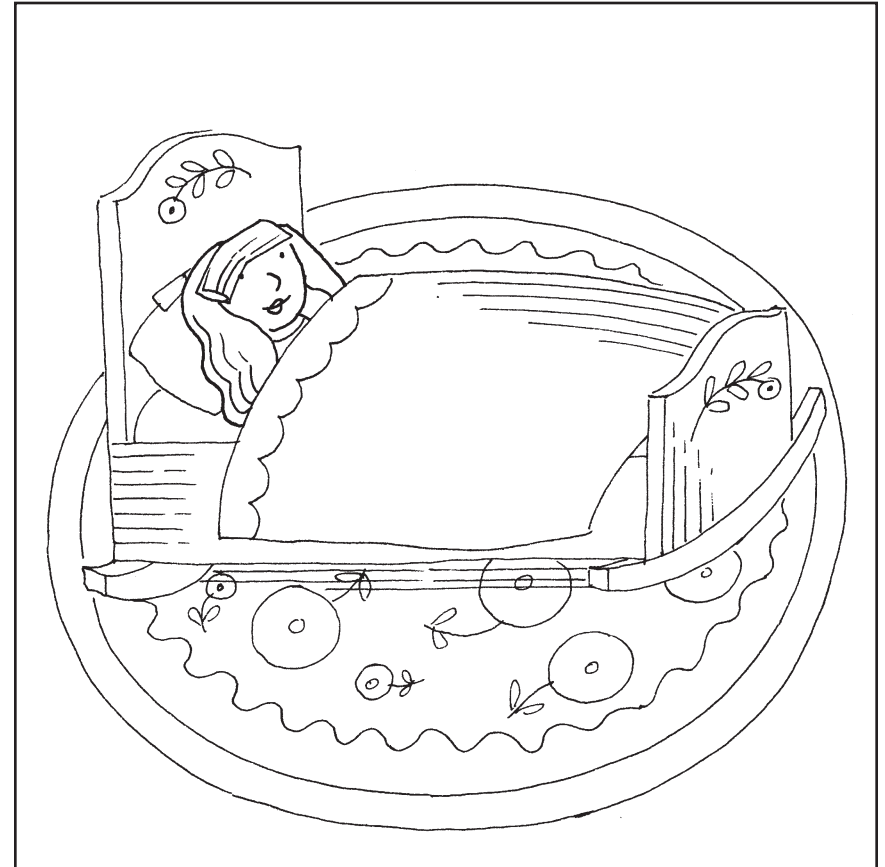

**High-Frequency Words Taught to Date**

a	brown	family	help	most	pushed	their	who
about	buy	far	her	mother	put	there	why
above	by	father	here	my	read	these	window
across	call	few	high	myself	ready	they	with
after	car	field	hold	near	right	think	work
again	carry	find	house	never	said	those	world
all	caught	first	how	new	school	thought	would
almost	city	five	I	night	second	three	write
along	cold	fly	idea	no	see	to	years
always	come	follow	into	noise	seven	today	yellow
and	could	food	is	nothing	shall	together	you
animal	country	for	kinds	now	she	too	young
are	covers	four	know	of	should	took	your
around	cried	friend	large	off	show	toward	
away	different	friendship	laugh	old	sing	try	air
baby	do	full	learning	once	small	two	cheer
ball	does	funny	light	one	soil	under	children
be	done	give	like	only	some	until	hello
bear	don't	go	listen	open	sometimes	use	hundred
beautiful	door	goes	little	or	soon	very	mind
because	down	good	live	our	sorry	walk	next
been	draw	great	long	out	starts	want	other
before	earth	green	look	over	stories	warms	pretty
began	eat	ground	loudly	own	story	was	says
begins	eight	grow	loved	paper	studied	wash	sleep
bird	enough	happy	make	party	sure	watch	table
blue	even	have	many	people	surprised	water	this
both	every	he	maybe	pictures	take	we	told
boy	everyone	head	me	play	talk	were	
bring	eyes	hear	minute	please	teacher	what	
brothers	fall	heard	more	pull	the	where	

**Decoding skills taught to date:** short *a*; short *i*; closed syllables (CVC: short *a*, *l*); short *o*; short *u*; short *e*; closed syllables (CVC: short *o*, *u*, *e*); long *a* (CVCe); long *i* (CVCe); /k/ spelled *c*; /s/ spelled *c*; long *o* (CVCe); long *u* /yōō/ (CVCe); long *u* /ōō/ (CVCe); long *e* (CVCe); /g/ spelled *g*; /j/ spelled *g*, *dge*; blends with *r*; blends with *l*; blends with *s*; final blend *nd*; final blend *ng*; final blend *nk*; final blend *nt*; double final consonants *ll*; consonants; short vowels; /z/ spelled *s*; inflection *-s*; final blend *mp*





Lill puts Dell in bed. Lill is glad that Dell is here.

# Dell



See Lill and her doll, Dell. Dell is new. Dell is a pal.

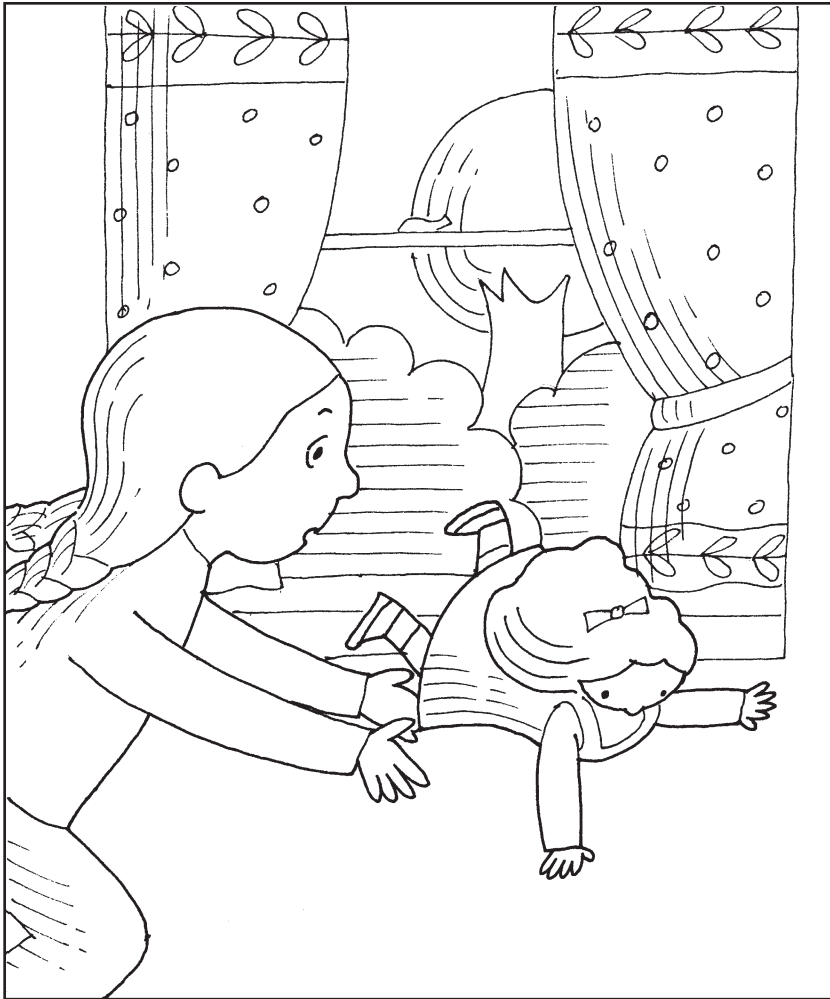

Lill put Dell on a sill. Dell fell. Lill ran to help. Lill can get Dell well.



"You fell, Dell," said Lill. "This is not fun. You got a bad bump. I will help you get well, Dell."

# Jill and Bill

## DECODABLE WORDS

Target Skill: double final consonants //

Bill	fill	hill	hills	Jill
------	------	------	-------	------

## Previously Taught Skills

and	dog	hot	pants	up
best	get	it	ran	
big	gets	lap	run	
can	has	likes	runs	
cup	help	pan	stop	

SKILLS APPLIED IN WORDS IN STORY: short *a*; short *i*; short *o*; short *u*; short *e*; closed syllables (CVC); /k/ spelled *c*; /g/ spelled *g*; final blend *nd*; final blend *nt*; double final consonants //; consonants; short vowels; /z/ spelled *s*; inflection -s; final blend *st*; blends with *l*; blends with *s*

## HIGH-FREQUENCY WORDS

a	friend	my	to
are	friend(s)	play	too
down	her	play(s)	we
for	I	said	with

# Jill and Bill



**High-Frequency Words Taught to Date**

a	brown	family	help	most	pushed	their	who
about	buy	far	her	mother	put	there	why
above	by	father	here	my	read	these	window
across	call	few	high	myself	ready	they	with
after	car	field	hold	near	right	think	work
again	carry	find	house	never	said	those	world
all	caught	first	how	new	school	thought	would
almost	city	five	I	night	second	three	write
along	cold	fly	idea	no	see	to	years
always	come	follow	into	noise	seven	today	yellow
and	could	food	is	nothing	shall	together	you
animal	country	for	kinds	now	she	too	young
are	covers	four	know	of	should	took	your
around	cried	friend	large	off	show	toward	
away	different	friendship	laugh	old	sing	try	air
baby	do	full	learning	once	small	two	cheer
ball	does	funny	light	one	soil	under	children
be	done	give	like	only	some	until	hello
bear	don't	go	listen	open	sometimes	use	hundred
beautiful	door	goes	little	or	soon	very	mind
because	down	good	live	our	sorry	walk	next
been	draw	great	long	out	starts	want	other
before	earth	green	look	over	stories	warms	pretty
began	eat	ground	loudly	own	story	was	says
begins	eight	grow	loved	paper	studied	wash	sleep
bird	enough	happy	make	party	sure	watch	table
blue	even	have	many	people	surprised	water	this
both	every	he	maybe	pictures	take	we	told
boy	everyone	head	me	play	talk	were	
bring	eyes	hear	minute	please	teacher	what	
brothers	fall	heard	more	pull	the	where	

**Decoding skills taught to date:** short *a*; short *i*; short *o*; short *u*; short *e*; closed syllables (CVC); long *a* (CVCe); long *i* (CVCe); /k/ spelled *c*; /s/ spelled *c*; long *o* (CVCe); long *u* /yōō/(CVCe); long *u* /ōō/ (CVCe); long *e* (CVCe); /g/ spelled *g*; /j/ spelled *g*, *dge*; blends with *r*; blends with *l*; blends with *s*; final blend *nd*; final blend *ng*; final blend *nk*; final blend *nt*; double final consonants *ll*; consonants; short vowels; /z/ spelled *s*; inflection -s; final blend *st*; blends with *t*; blends with *s*



Jill can fill a pan for Bill. Jill can fill a cup, too.

Jill said, "Bill can lap it up. I can help my best friend, Bill."

# Jill and Bill



Jill has her dog, Bill. Jill and Bill are best friends.

Jill and Bill ran down a big hill.



Jill plays with Bill. Bill runs. "Get it, Bill," said Jill. Bill likes to run up and down hills, and Jill likes to play with Bill.



Jill and Bill ran and ran. Jill gets hot. Bill pants and pants. "We can stop," said Jill.